







**1.1**

**1.1.1**

**3 80 / 1.5 /**



q,DyÜ P

P 3\$' "e' \$G•²@đ Tt' €'q

'Veú\$@B rB€%Rv/R\$'i@đ4P@..` —e P FBp%o Å—e å Q ^ 1 —e

### **1.1.3**

### **1.1.4 LDA**

Y  
Q  
R

## 1.3

1

2

3









**1** .....**1-1**

**5** ..... **5-1**

**6** ..... **6-1**

**7** ..... **7-1**

**8** ..... **8-1**

**9** ..... **9-1**

**10** ..... **10-1**

**11** ..... **11-1**



---

---

# 1

## 1.1

### 1.1.1

2014  
201 24  
201 16  
201 0  
2020 43  
201  
200 6  
201 24  
201 16  
201 16  
201 16  
201 32  
2010 3

### 1.1.2

6 2  
641  
5 1  
2011 35  
2013 3  
2015 1  
2016 31  
2016  
2016 65  
2016 4  
201 22

---

---

201 6 16

**1.1.3**

5

3

1

34

201

201

11

3

4

201

2

2010 5

2011 5

200 302

2012

2012

2013 103

2013 104

2014 1

2015 4

2015 162

2015 163

---

---

2015 1

2016

2016 150

2016 1 0

2016 16 6

201 43

201 121

201 4

201 123

201 0

201 53

201 0

201 2

2020

201 3

2020 13

201 4

---

---

**1.1.4**

				4	201	11	
30							
				2	201		21
				41	201	11	30

233

233

4 201 11 30

3

311

2005 3

2006 2

200 6

200 56

2011 14

2011 35

2012 1

2013 13

2014 126

---

2014 56

2015 31

2015 4

2015 231

2015 25

2015 14

2016 4

2013 2020

201 2020

201 1

2016 3

2016 141

2016 14

2016 162

2016 1 4

2016-2020

2016 1 6

201 10

201 151

---

201

201 150

201

201 260

201 331

201 452

201 561

201

2020

201 166

201 5

201 -2020

201 36

201 132

201 112

201 166

201 1134

201 24

201 113

---

201 1 0

201 146

201 14

201 13

52

201 312

2020

2020 2

2020 2

2020 30

2020 40

### 1.1.5

2011 2020

2003 2020

2004.11

2003

2012 2

2012 20

2014 3

2015 5

2015 10



2016 5

2016-2020

2016 13

2016 16

2016 3

201 1

201

201

201 22

201 -2020 )

201 13

201 -2020

201 44

201 12 25

201 4

201 4

201

6 6

201 2

---

201 25

201 25

---

---

610-2016)

1 -2011

/ 16 -201

64-201

2001 1

1 21 -201

/ 504 3-201

2000-2011

2015-2012

2025-2012

5 -2010

1226 -2012

663-2013

2011 22

/ 3 3-200

( / 3024-201 )

50 34-2013

34330 201

3 / 2643-2014

31

2014 1

2016

5

/ 3 40- 1

30 3-1

1 -201

53-201

34330-201

4-201

2-201

---

---

0-201

1 -201

**1.1.**

120 /

200 00 2010 0001

200 /

2015 1 4 2015 204

0 / 1.5 /

2016 1 2

20 / / 4

2016 1 3

160 /

2016 1 1

201 2

350 <sup>3</sup>/

201 1

2 40 /

201 1

0 /

201 15

**1.2**

**1.2.1**

**DAVIDSON**

4

1.2.2

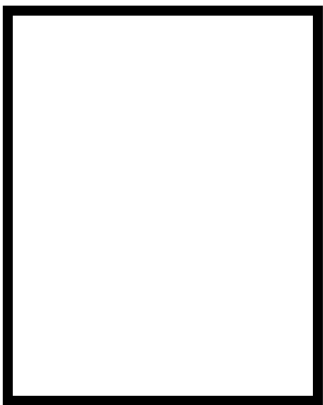

**JOBBE**

			--
		--	
			--

1.3-2

**1.3-2**

		2 2 10 2.5 3	2 2 10 2.5 3
		5	5
		2  + + 2+ + 3 <sup>2-</sup> 3 <sup>-</sup> - 4 <sup>2-</sup>	2
		36600	36600

**1.4**

1.4 On G.

**1.4-1**

		/	/ 3	/ 3	%	10%
	2	0.014	.06 -05	0.5	0.02	
01		0.55	3.22 -03	0.2	1.61	
		0.045	2.5 -04	0.	0.03	
	2	0.014	1.11 -04	0.5	0.02	
020		0.311	2.4 -03	0.2	1.24	
		0.040	3.1 -04	0.	0.04	
	2	0.014	1. -04	0.5	0.04	
021		0.10	1.54 -03	0.2	0.	
		0.011	1.56 -04	0.	0.02	
	2	0.026	2.30 -04	0.5	0.05	
022		0.21	1. 6 -03	0.2	0. 3	
		0.041	3.62 -04	0.	0.04	
	2	0.4	1.12 -03	0.5	0.22	
002		0.2	6.65 -04	0.2	0.33	
		0.14	3.32 -04	0.	0.04	
	2	0.036	.14 -05	0.5	0.02	
011		0.0 6	2.44 -04	0.2	0.12	
		0.0 3	2.11 -04	0.	0.02	
	2	0.053	1.10 -04	0.5	0.02	
010		2.341	4. 6 -03	0.2	2.43	
		0.14	3.0 -04	0.	0.03	
		0.011	.52 -04	0.2	0.3	
01		0.0001	6. 4 -06	0.01	0.0	
		0.0	6.16 -03	2.0	0.31	
1		0.264	6.53 -02	2.0	3.2	
2		11. 5	1.2 +00	2.0	63.65	1 50
3		0.311	1.06 -01	2.0	5.2	
4		0.005	2.53 -03	2.0	0.13	
		0.0023	1.16 -03	0.01	11.65	5
5		0.0025	.0 -04	2.0	0.05	
		0.0023	.36 -04	0.01	.36	
6		0.12	4. 5 -02	2.0	2.42	
		0.216	1.04 -01	2.0	5.20	
		0.005	1.4 -03	0.2	0. 5	
		0.0000	2.02 -05	0.01	0.20	
		0.002	.0 -04	2.0	0.04	

63.65%

10%

1 50

10%

---

---

1.4-1

**1.4-1**

		/ <sup>3/</sup>		
		/		
		20000	600000	
				200
		200	6000	41 .61 <sup>3/</sup>

**1.4-2**

	63.65% 10% 1 50 10%	
	10	
	200	
	610-2016	
	30 6-200 3 3	
	5.6	
	16000 <sup>2</sup> 1.6 <sup>2</sup>	
	5 <sup>2</sup>	

**1.4.2**

**1.5**

**1.5.1**

1.5-1 1.5-1

**1.5-1**

	10 5
	3 1.5
	500 3400
	200
	5
	1000

	1
--	---

1.5.2

2

150

00

500

22

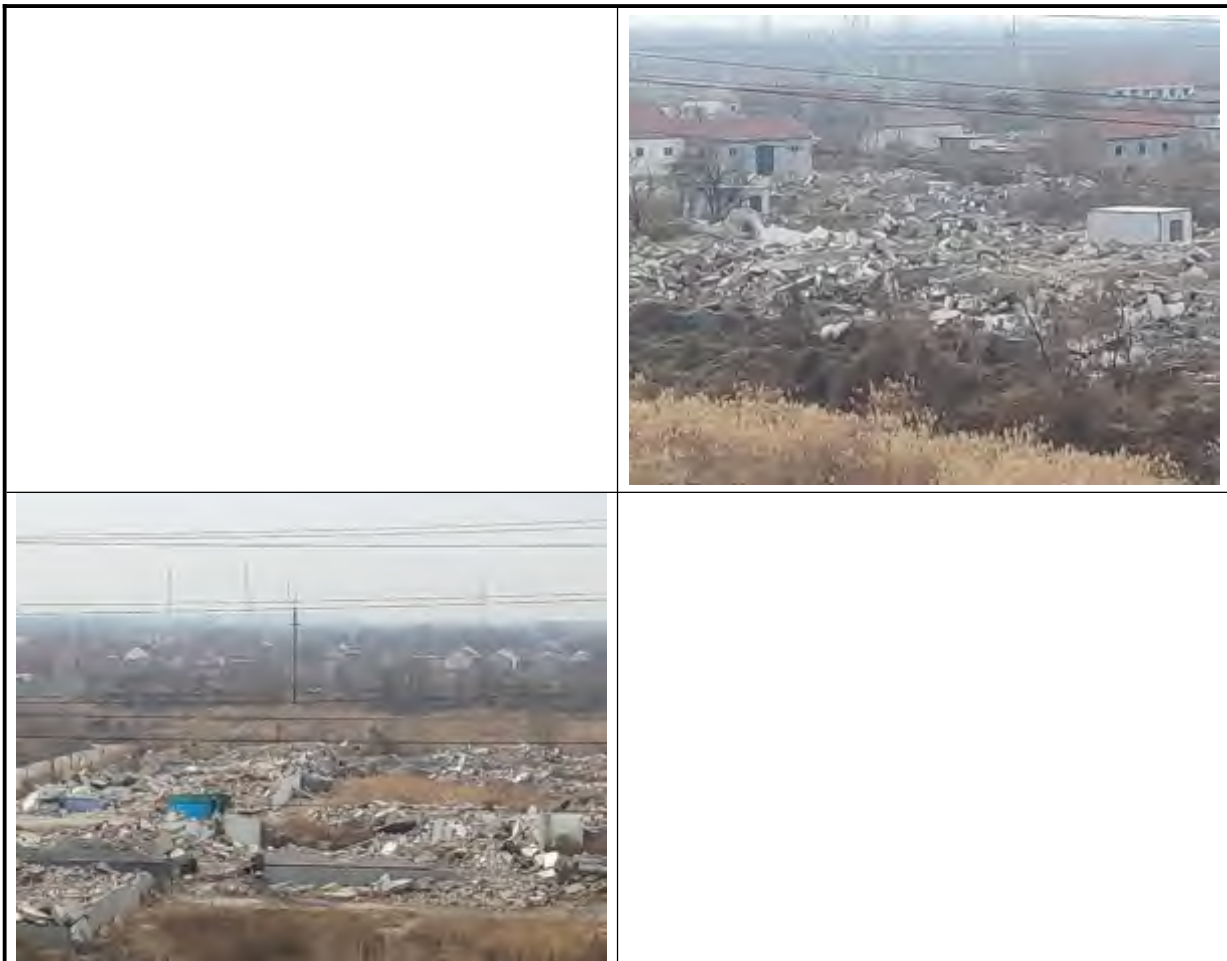

1.5-1

1.5-2

1.5-1

1.5-2

		1			-1311	56	6 3	564
		2			562	-11	1050	65
		3			12 4	-412	30	6
		4			1	-356	1300	560
		5			1 36	-63	1350	322
		6			1 5	-506	13 0	41
					254	-450	1 50	150
					2454	-6 3	1 00	650
					3034	-61	2200	654
		10			3165	-431	2300	52
		11			2060	-104	1650	634
		12			3 5	- 1	2 50	25
		13			4121	- 6	3150	1050
		14			3 65	-524	2 50	6
		15			1 2	-1311	1 50	560
		16			211	-1630	2130	322
		1			252	-166	2250	41
		1			2 03	-1330	2420	150
		1			44	-356	3210	650
		20			41	-300	3050	200
		21			4551	-56	3050	52
		22			4 64	1	3620	634
5		23			53 6	-262	4010	25
		24			5 06	- 43	43 0	6
		25			55 2	-10 6	4350	560
		26			505	-1161	4010	322
		2			6 62	-13 6	5320	41
		2			5 3	-1 4	4 50	150
		2			64	-2135	5400	650
		30			4 0	-24 1	4350	350
		31			54	-2 2	5040	52
		32			5 5	-2 2	53 0	54
		33			5 63	-42 0	6060	635
		34			62 5	-4 6	6620	442
		35			443	-3	5110	345
		36			42	-3503	4 0	6
		3			3 6	-3240	42 0	52
		3			31 4	-2 4	3 10	462
		3			3165	-445	4 30	6
		40			2510	-4102	4360	54
		41			254	-35 6	4200	63
		42			2004	-33 0	3510	52
		43			2566	-5001	5230	1500

		44			20	-4 64	5100	41
		45			11	-505	5220	150
		46			1311	-4 5	5150	650
		4			12 4	-3 6	4200	200
		4			5	-40 3	3 00	52
		4			- 4	-2641	23 0	634
		50			-1	-2341	2300	25
		51			4	-20	1 0	6
		52			656	-2641	23 0	560
		53			4	-2 35	2450	1520
		54			-543	-2004	1 00	1630
		55			-6 3	-1 1	1 20	41
		56			-1124	-16 6	16 0	150
		5			-1555	-1442	1550	650
		5			-1424	-2454	2460	200
		5			-20	-2135	23 0	52
		60			-252	-20	25 0	634
		61			-3334	-2304	2 50	25
		62			-3034	-30 2	36 0	6
		63			-2510	-3315	3520	560
		64			-314	-35	43 0	322
		65			-34 4	-3 65	4410	41
		66			-31 4	-42	4 30	150
		6			-520	-32	5010	650
		6			-5 31	-2 2	5150	350
		6			-53 6	-1555	4540	52
		0			-4 5	-151	4020	54
		1			-565	-562	4030	635
		2			-550	0	40 0	442
		3			-50 6	15 3	4100	345
		4			-4 26	22 5	4130	6
		5			-5600	4102	5230	41
		6			-4 64	4 3	5 60	150
					-31 4	2341	2 30	650
					-2 22	3165	35 0	200
					-2 10	0	2120	52
		0			-340	21 3	2 50	634
		1			- 4	1536	1310	25
		2			-1	1 3	1 0	6
		3			- 12	3634	3150	560
		4			-2023	40 3	4160	322
		5			-2566	43 3	4250	41
		6			-22 5	4 0	45 0	150
					506	45	46 0	6
					1105	3503	3310	350
					2304	3652	3 50	52
		0			3315	3 0	3 0	54

		1			14 0	1 23	1 00	635
		2			2341	24 2	2 20	442
		3			254	1424	2020	345
		4			3165	1405	2420	6
		5			3 4	3315	4160	650
		6			4664	415	51 0	364
					5600	3652	5060	52
					66	3 46	5 30	634
					4664	4 5	5630	25
		100			5001	4514	5650	6
		101			5451	44 5	56 0	560
		102			5432	5 1	4010	322
		103			5 63	106	4 50	41
	500 3400	1					1	--
			3			1.5	13.5 <sup>2</sup>	
							1000	
			200					

1.

1. .1

1. -1

			--
	--		--
	3	3	--
			--

1. .2

0 /

1.6-2 1.6-2

**1. -2**

	30 5-2012	
	2.2-201	
	( 162 -1 6)	
	3 3 -2002	
	/ 14 4 -201	
	30 6-200	3
	36600-201	

**1. -3**

1	2		/ 3	60	30 5-2012
		24	/ 3	150	
		1	/ 3	500	
2	2		/ 3	40	
		24	/ 3	0	
		1	/ 3	200	
3	10 10		/ 3	0	
		24	/ 3	150	
4	2.5 2.5		/ 3	35	
		24	/ 3	5	
5		24	/ 3	4	
		1	/ 3	10	
6			/ 3	100	
		1	/ 3	160	
1		1	/ 3	3.0	2.2-201
2		1	/ 3	0.01	
3		1	/ 3	0.2	
4		1	/ 3	2.0	

**1. -4**

				5			
	6	2	40	10	2.0	0.2	0.1
	0.001	0.1	0.4	250	1.5	1.0	250

	0.01	0.	0.5	0.1	1.0	1000	0.2
	1.0	0.02	0.3		2.0	0.1	0.01

**1. -5** /

		/ 14 4 -201	/
1			6.5 .5
2	3		450
3			1000
4			250
5			250
6	2		3.0
			0.5
			20
			1.00
10			1.0
11			0.05
12			0.3
13			1.00
14			1.00
15			0.005
16			3.0
1			0.10
1			0.001
1			0.01
20			0.01
21			0.002
22			0.05
23			100
24			0.02
25			0.02
26			0.03

1. -

.5 /

36600-201								
/	60	65	5.	1 000	00	3	00	4500
				1,1-	1,2-	1,1-	-1,2-	-1,2-
/	2.	0.	3		5	66	5 6	54
		1,2-	1,1,1,2-	1,1,2,2-		1,1,1-	1,1,2-	
/	616	5	10	6.	53	40	2.	2.
	1,2,3-				1,2-	1,4-		
/	0.5	0.43	4	2 0	560	20	2	12 0
			+			2-		
/	1200	5 0	640	6	260	2256	15	1.5
					1,2,3-			
/	15	151	12 3	1.5	15	0		

1. 3

1

2

3 /23 6-201

1

2 50 / 3

100 / 3

10 / 3

2

3 /23 6-201

1

2 100 / 3

200 / 3

20 / 3

3 /3161-201

1

10 / 3

20 / 3

3.0 / 3

100 / 3

00

6

3 /2 01.6-201

3

2.0 / 3

3 22-201

( 162 -1 6) 2

12 / 3

0.4 / 3

0.12 / 3

1.0 / 3

3 /3161-201 2 1.0 / 3  
 0.03 / 3 1.0 / 3 20  
 315 0-2015 3 5%

2

3 3 -2002

40 / 2.0 /  
 ( 3 /3416.5-201 ) 2

1 23-2005  
 1 20-2002

3

1 5 -2001  
 ( 1 5 2001)

4

1234 -200 3

65

55

1. -

				/ 3	/ 3
	3 /23 6-201	1	2	50	--
				100	--
				10	--
		1	2	100	--
				200	--
				20	--
	3 /3161-201	1		10	--
				20	--
				3	--
				00	--
				100	--
3 22-201			10 1	--	
			30	--	
( 162 -1 6)	2		--	1.0	
			--	12	
3 /2 01.6-201	3		--	2.0	
			--	1.0	

		3 /3161-201			--	1.0
					--	0.03
					--	20
		1234 -200	3	65		55
		12523-2011		65		55
		1 5 -2001				
		( 1 5 2001)				
		( 3 /3416.5-201 ) 2	2	5	10 /	
					20 /	
					0.5 /	
					650 /	
					1600 /	
		3 3 -2002			3 /	
					40 /	
		1 23-2005	1		2 /	
					60 /	
		1 20-2002			/	
					450 /	
					6.5- .5 /	
				5	10 /	

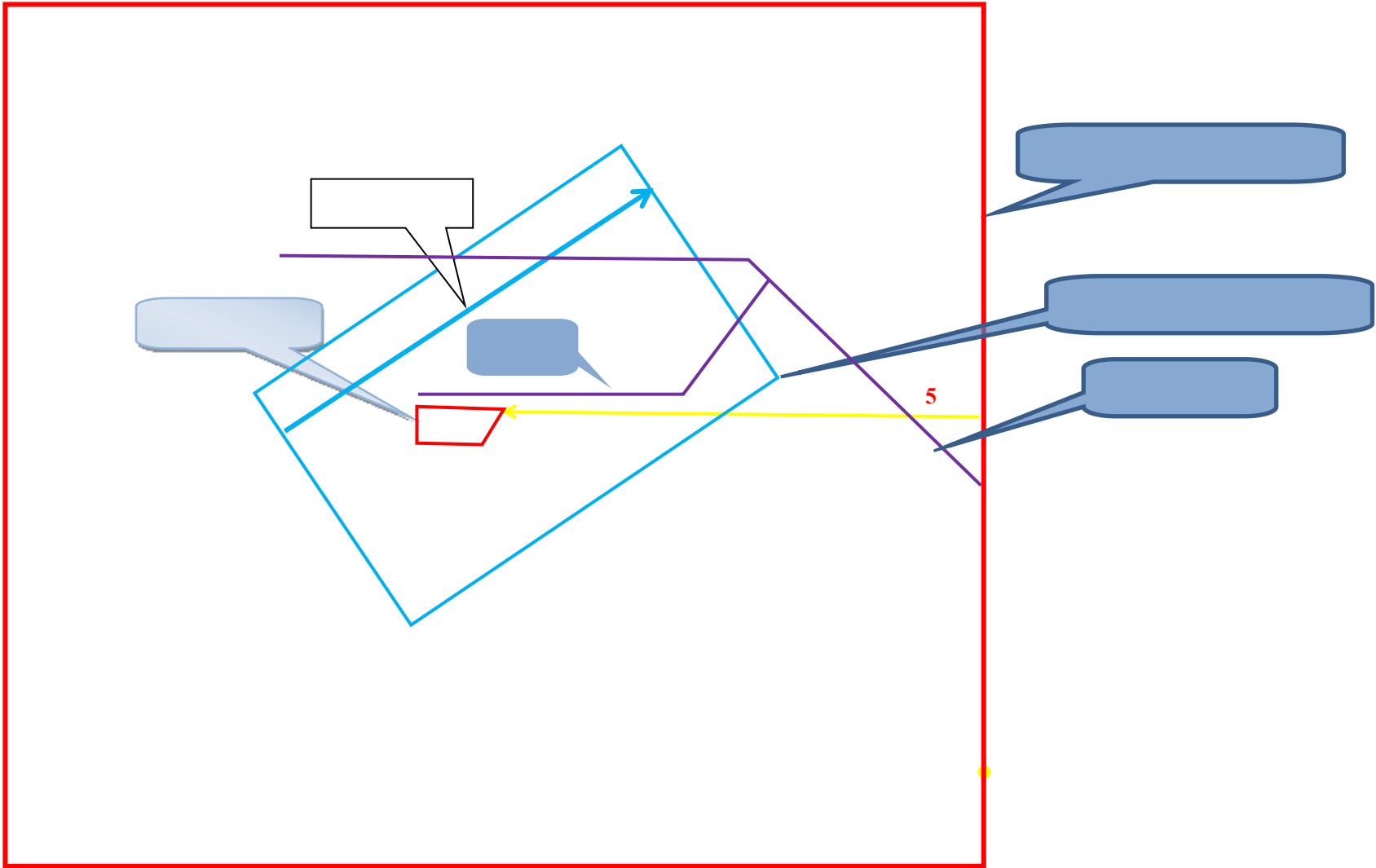

1.5-1

1 100000











<p>检测·报告 Testing Report 山中检字(2019)第DY217-a号</p> <p>项目·名称: 季度检测项目 委托·单位: 山东神驰化工集团有限公司 检测·类别: 委托检测 报告·日期: 2019.4.8</p> <p>山东中泽环境检测有限公司 Shandong Zhongze Environmental Testing</p>	
---	--

检·测·报·告

Testing · Report

山中检字 (2019) 第 DY217-b 号

项·目·名·称: 季度检测项目  
委·托·单·位: 山东神驰化工集团有限公司  
检·测·类·别: 委托检测  
报·告·日·期: 2019.6.15

山东中泽环境检测有限公司  
Shandong Zhong Ze Environmental Testing



检·测·报·告

Testing · Report

山中检字 (2019) 第 DY217-d 号

项·目·名·称: 第四季度检测项目  
委·托·单·位: 山东神驰化工集团有限公司  
检·测·类·别: 委托检测  
报·告·日·期: 2019.12.31

山东中泽环境检测有限公司  
Shandong Zhong Ze Environmental Testing



# 检·测·报·告

Testing · Report

山中检字 (2020) 第 DY126-a-②号

.....项·目·名·称: .....水质检测项目.....  
.....委·托·单·位: .....山东神驰化工集团有限公司.....  
.....检·测·类·别: .....送样检测.....  
.....报·告·日·期: .....2020.4.19.....

分件号(件一四)

山东中泽环境检测有限公司  
Shandong Zhong Ze Environmental Testing



# 检·测·报·告

Testing · Report

山中检字 (2020) 第 DY126-a-②号

.....项·目·名·称: .....地下水检测项目.....  
.....委·托·单·位: .....山东神驰化工集团有限公司.....  
.....检·测·类·别: .....委托检测.....  
.....报·告·日·期: .....2020.4.29.....

分件号(件一四)

山东中泽环境检测有限公司  
Shandong Zhong Ze Environmental Testing





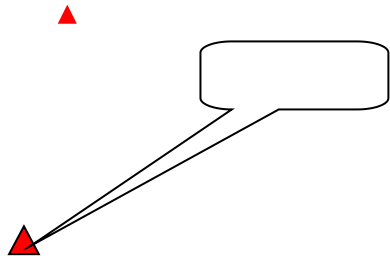



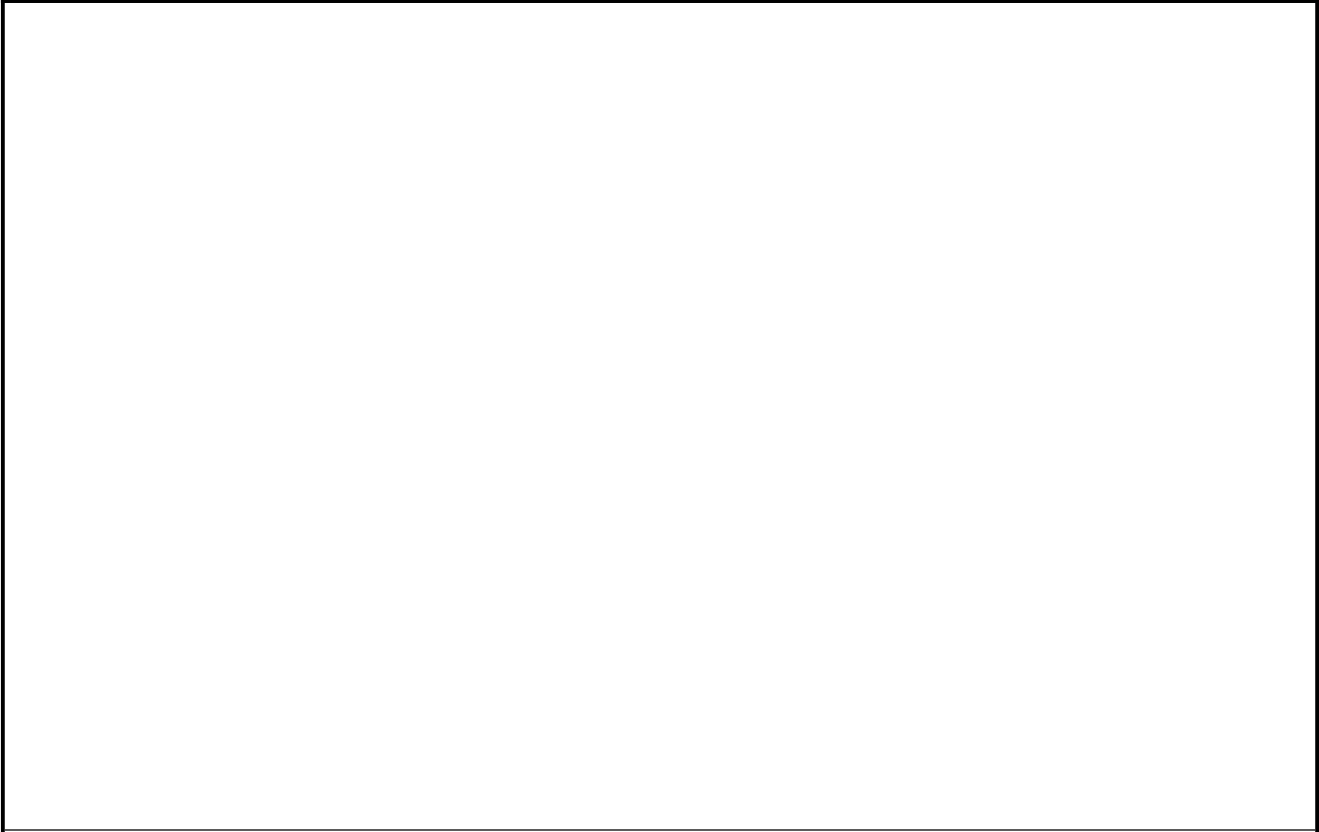

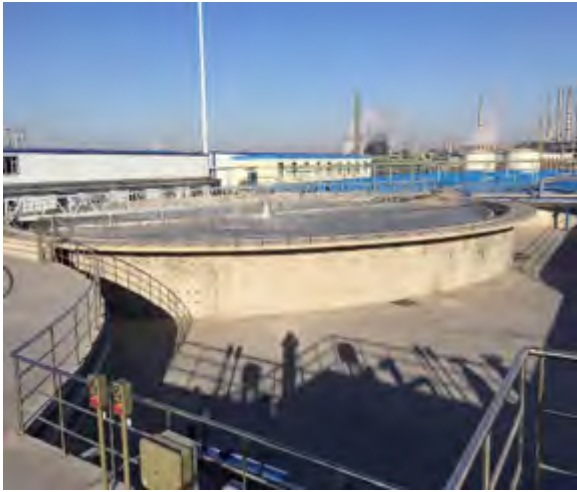

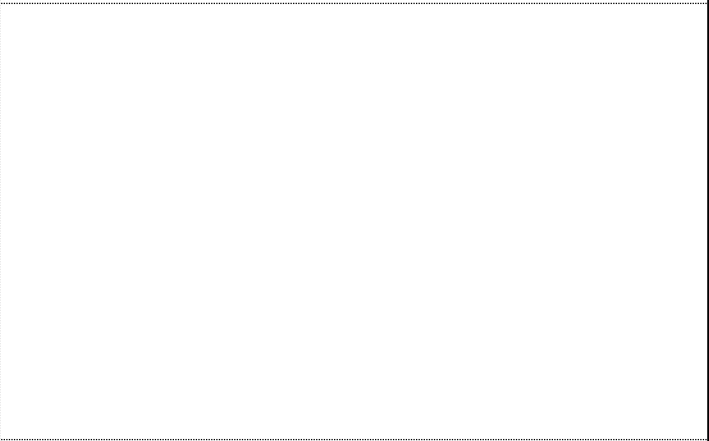
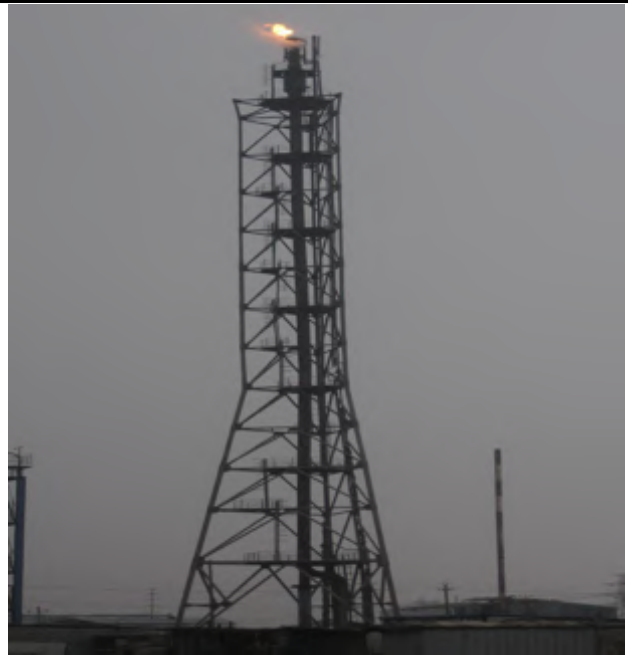

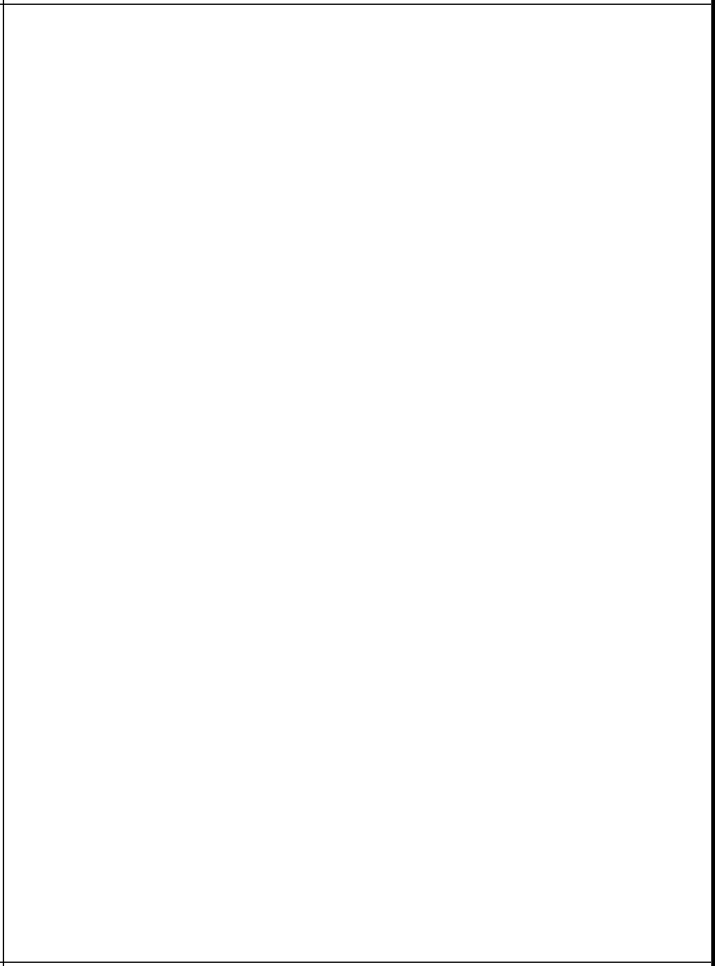
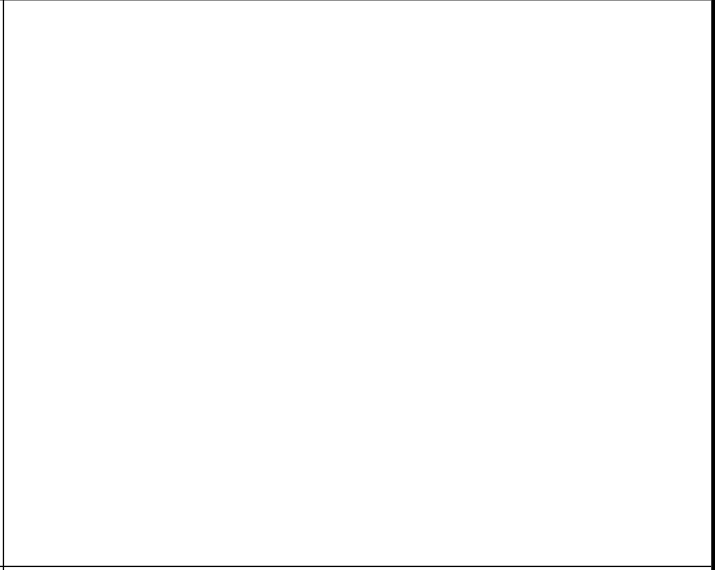
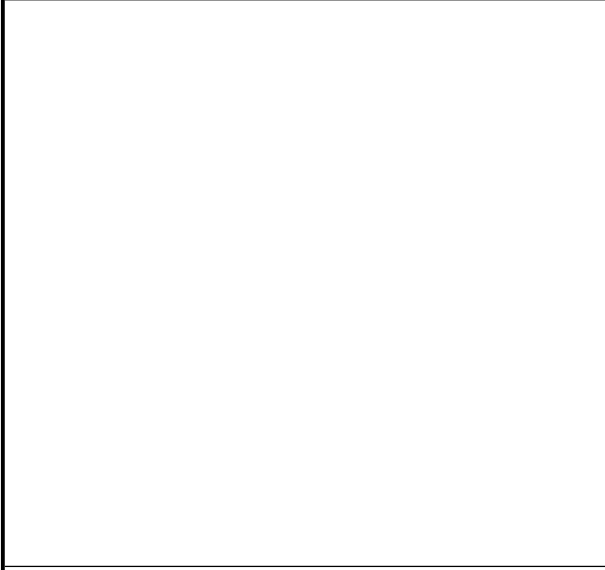



---

---









--	--	--

---

---



---

---



Ä





---

---





















































--	--	--	--	--	--	--	--	--

--	--	--	--	--	--	--	--	--

--	--	--	--	--	--	--	--	--

--	--	--	--	--	--	--	--	--





--	--	--	--	--	--	--	--	--

--	--	--	--	--	--	--	--	--











---

---

**T t } P**

---

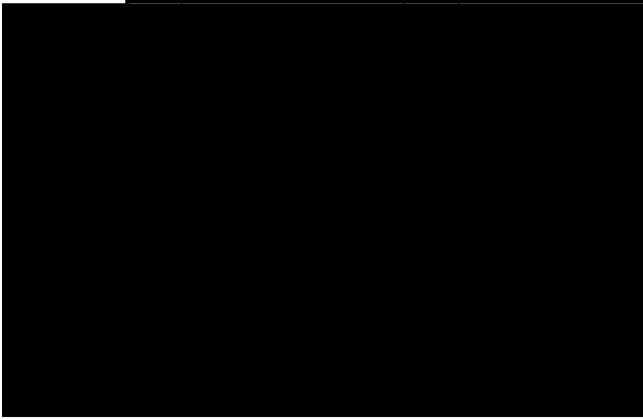
---





































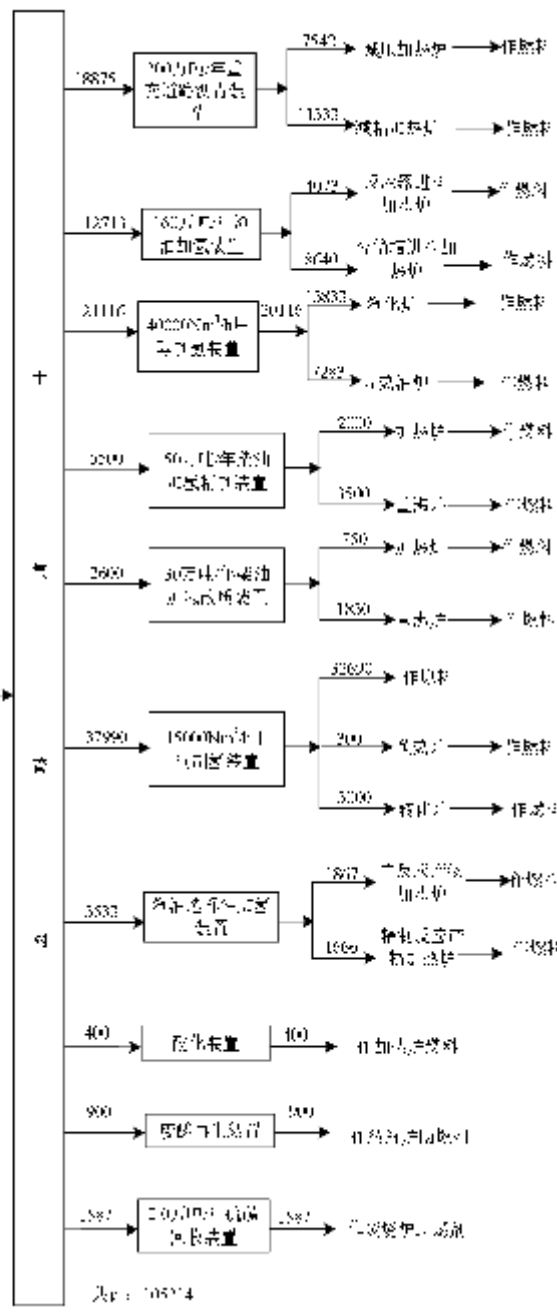
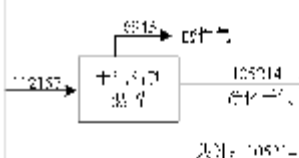
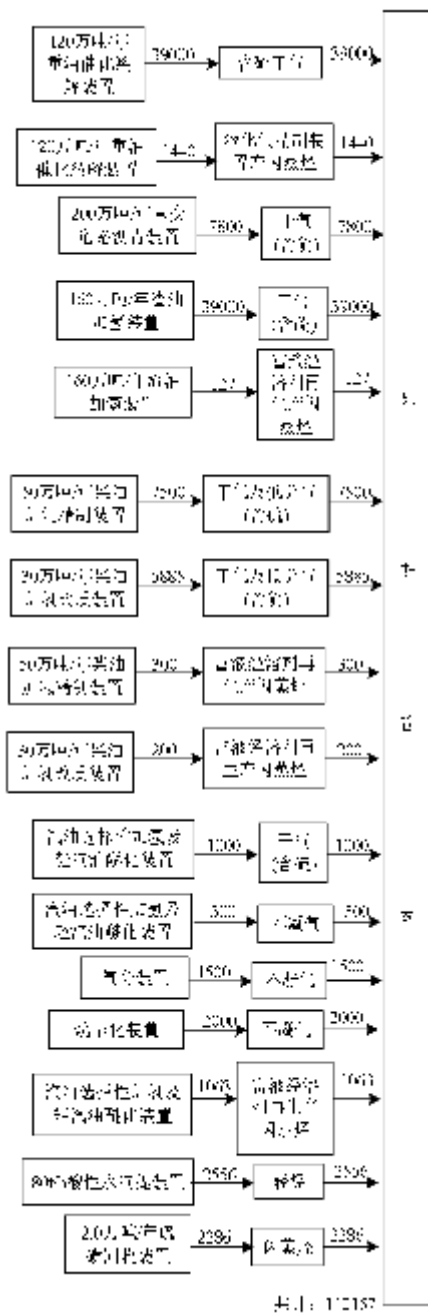





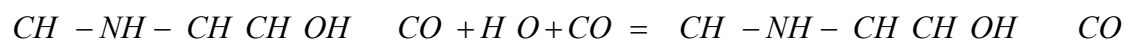
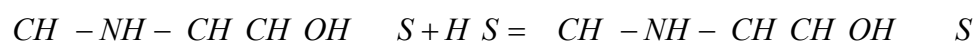
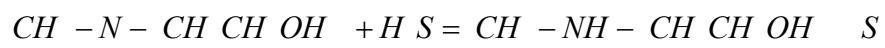

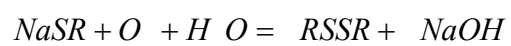
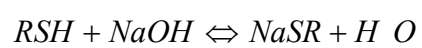

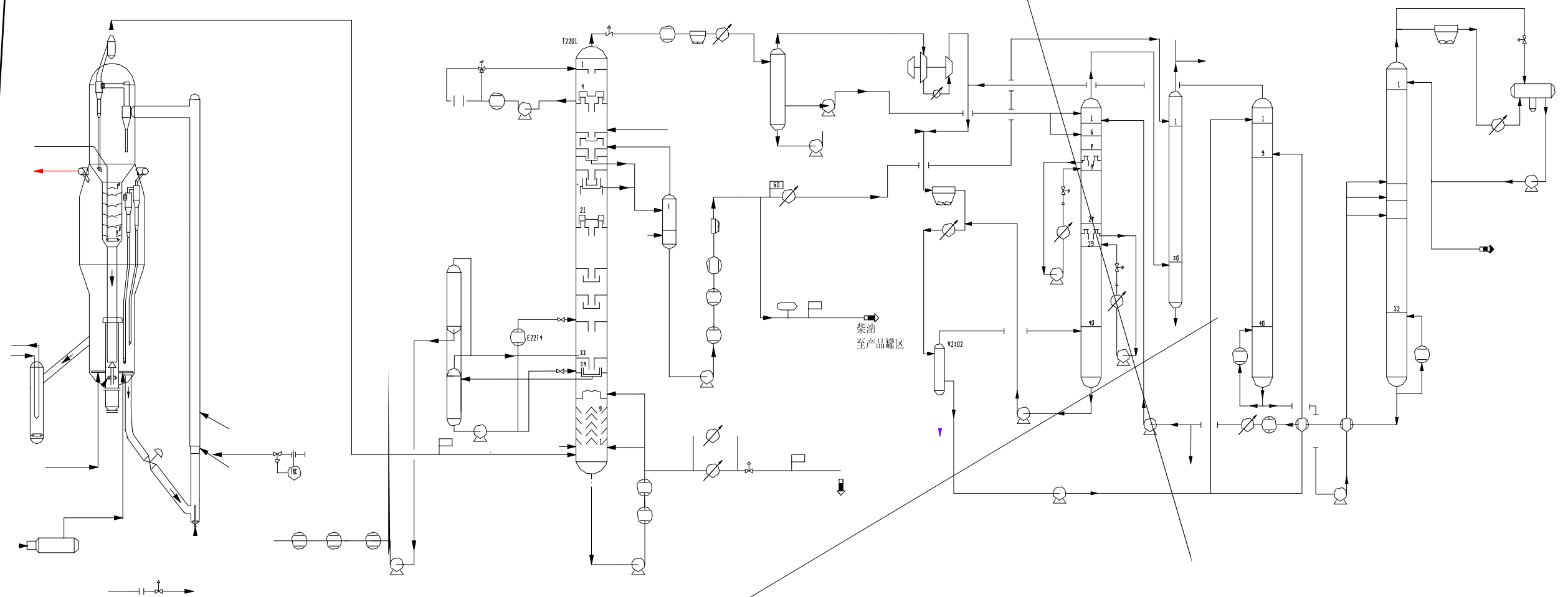

(•P!7u”Fs •!7uQts •!7 ±a0





'J \$EIPö GB,fi&äæ"© Á'

E^a•" B@ð TyBfieæ

Ð\.



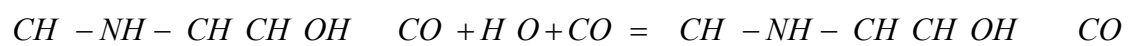
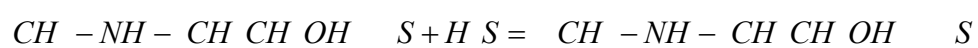
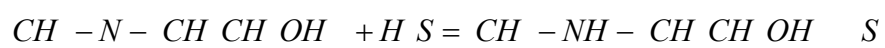













②

吡咯:

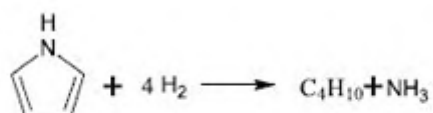

吲哚:

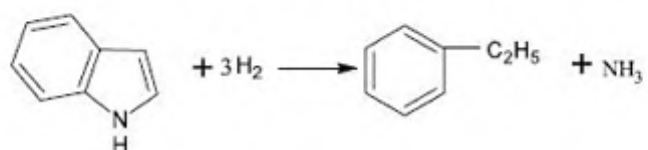

吡啶:

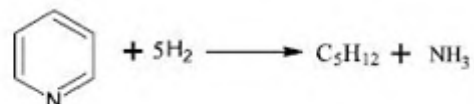

喹啉:



③加氢脱氧

酚类:



呋喃:

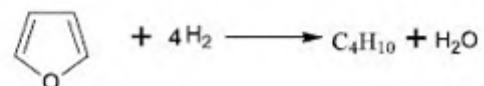









①

②

吡咯:

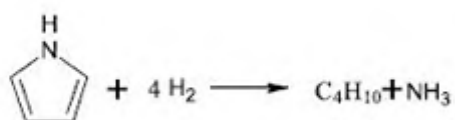

吲哚:

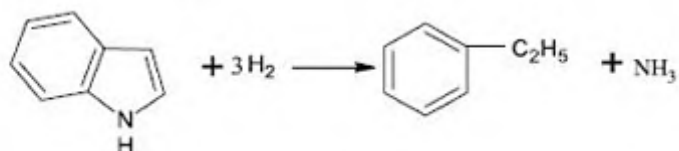

吡啶:

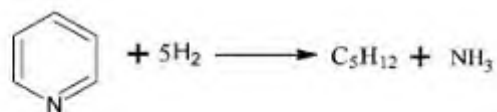

喹啉:



### ③加氢脱氧

酚类:

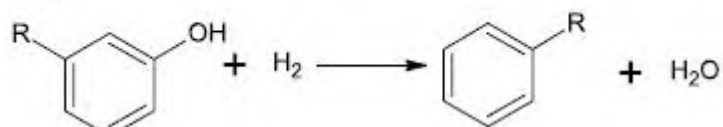

呋喃:

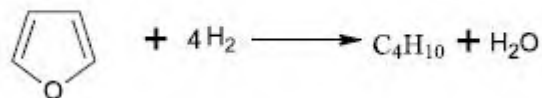

### ⑤芳烃加氢饱和

萘:

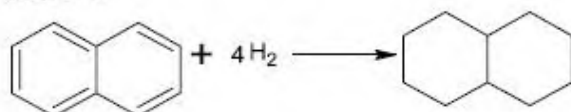

菲:

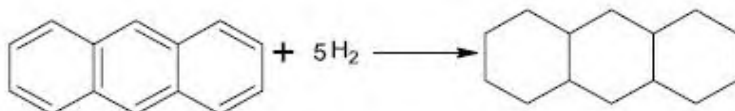







①

②

③



























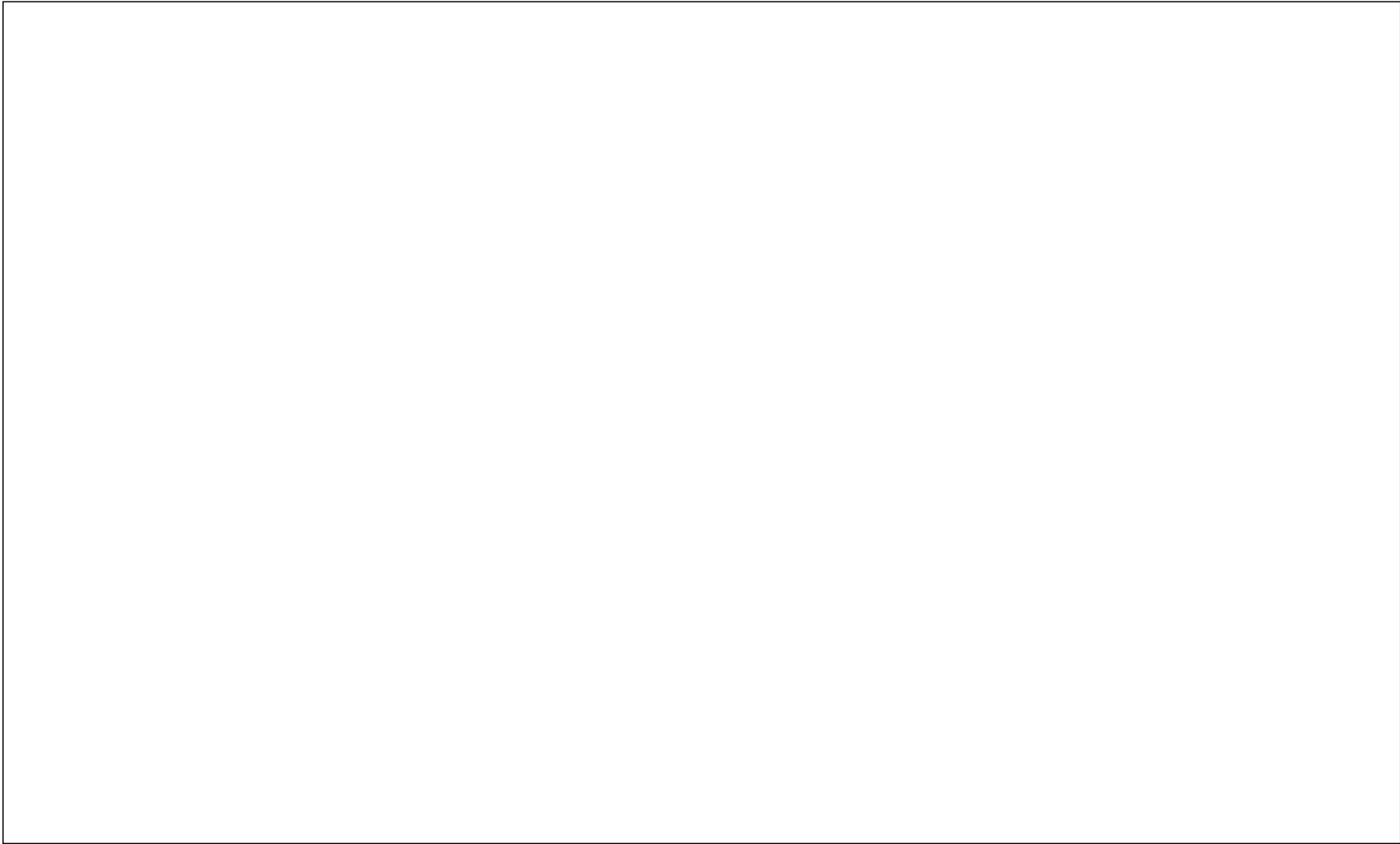

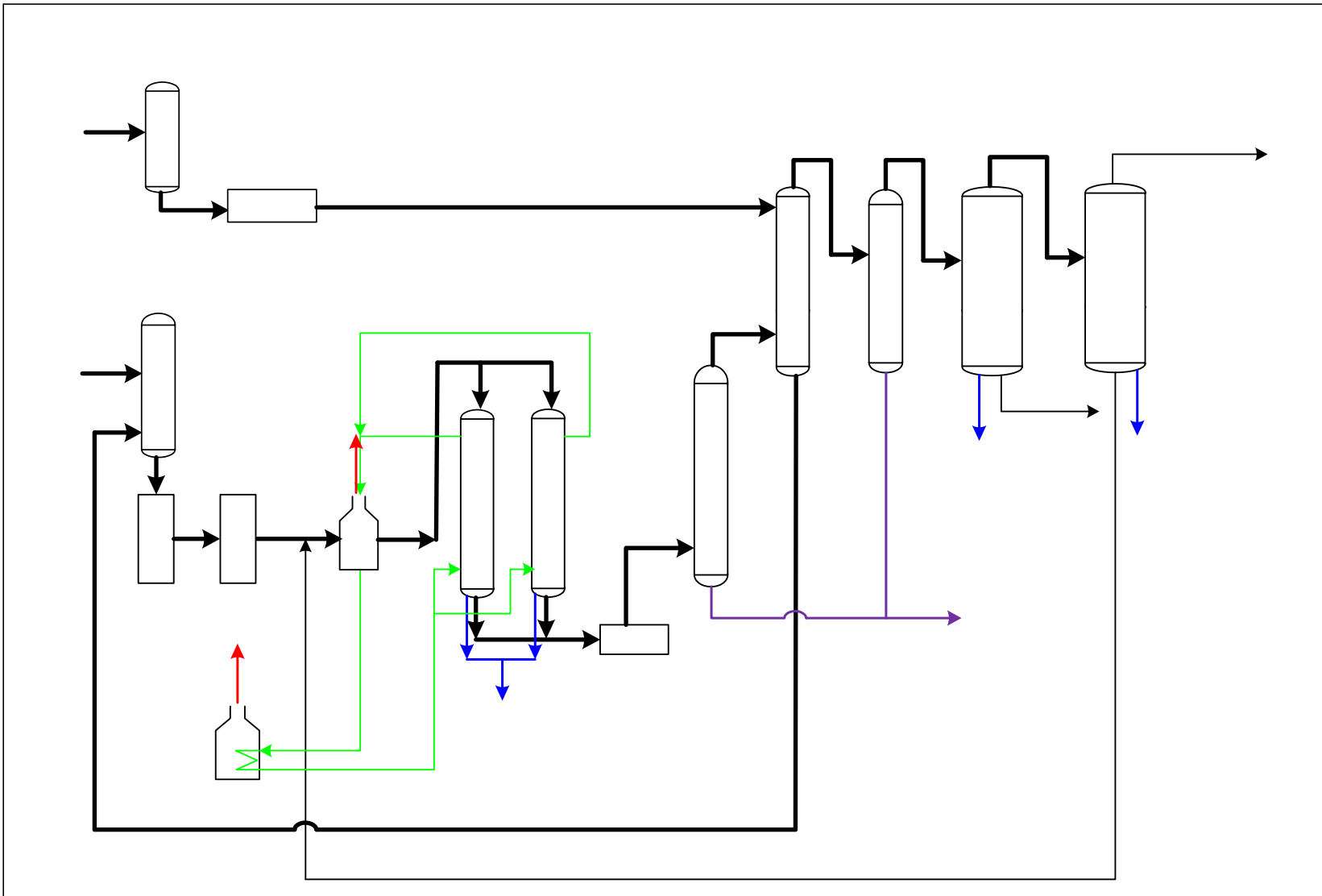









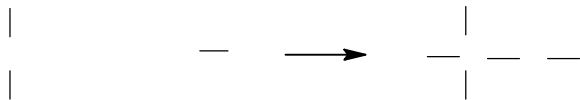

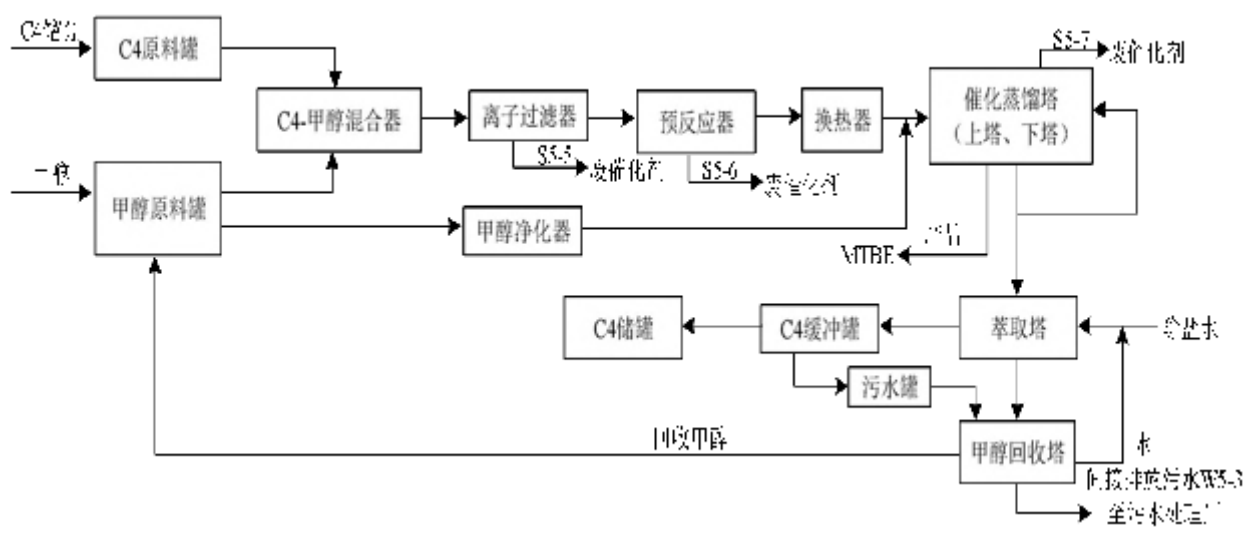









*wt*















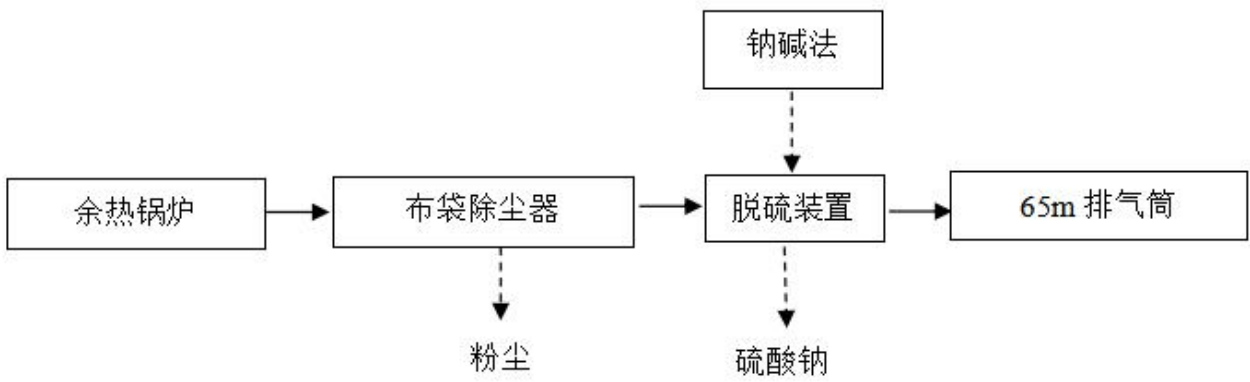

---

G 废气 W 废水  
N 噪声

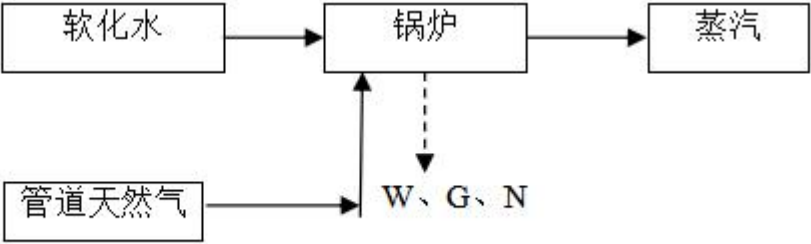





















































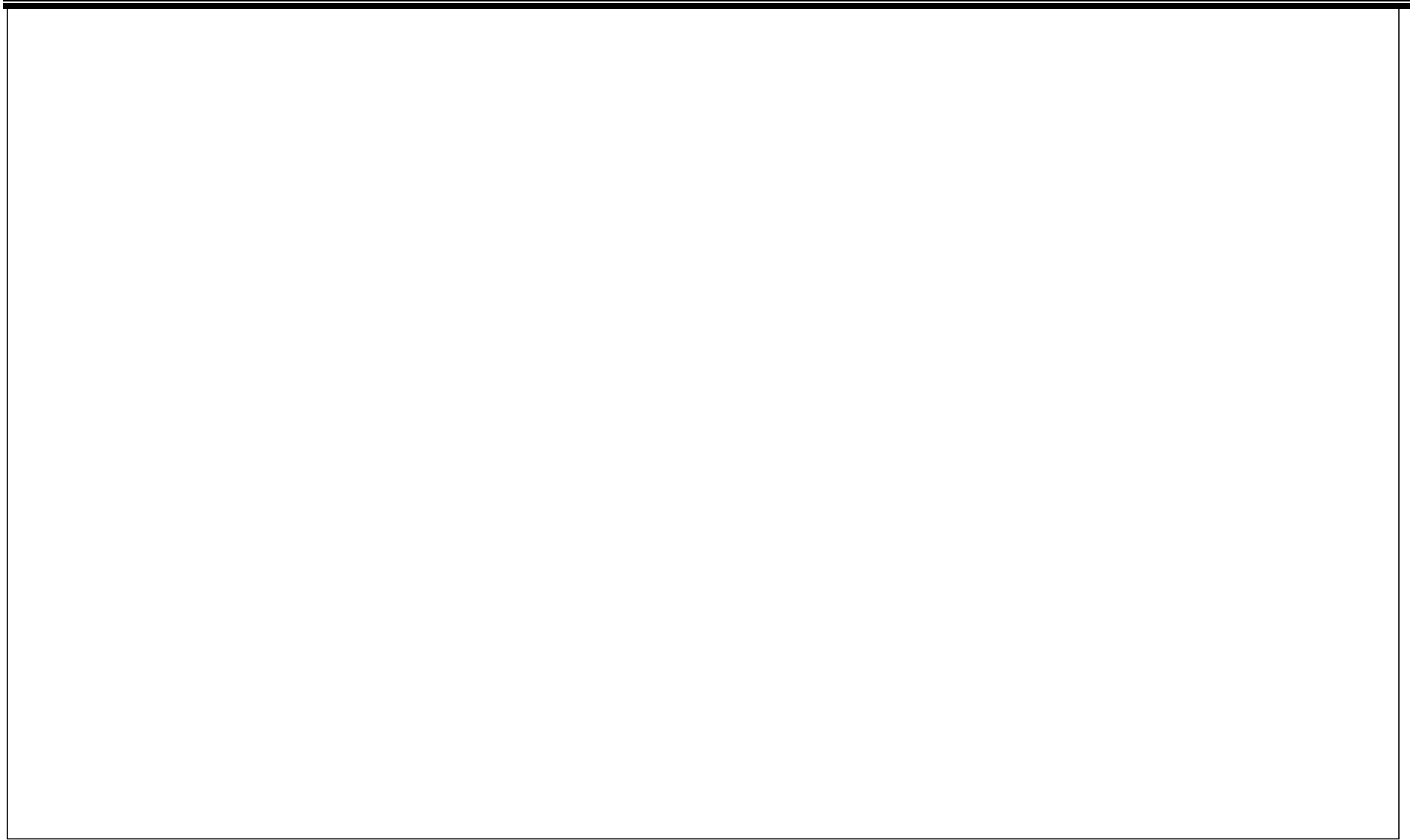































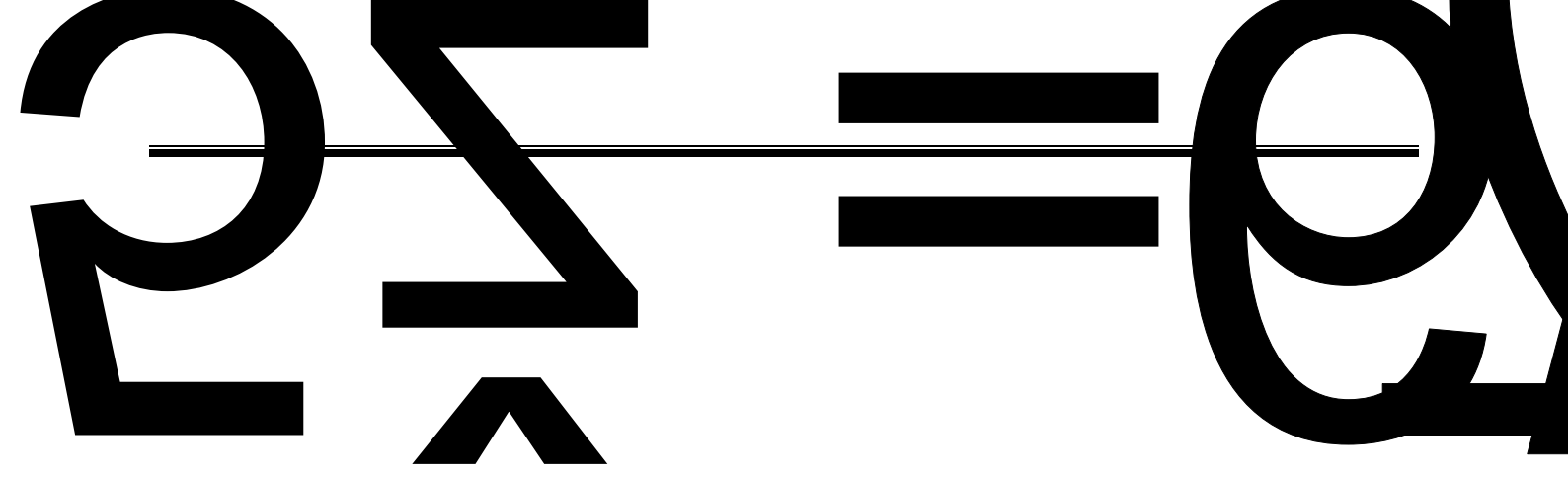

















































---

---







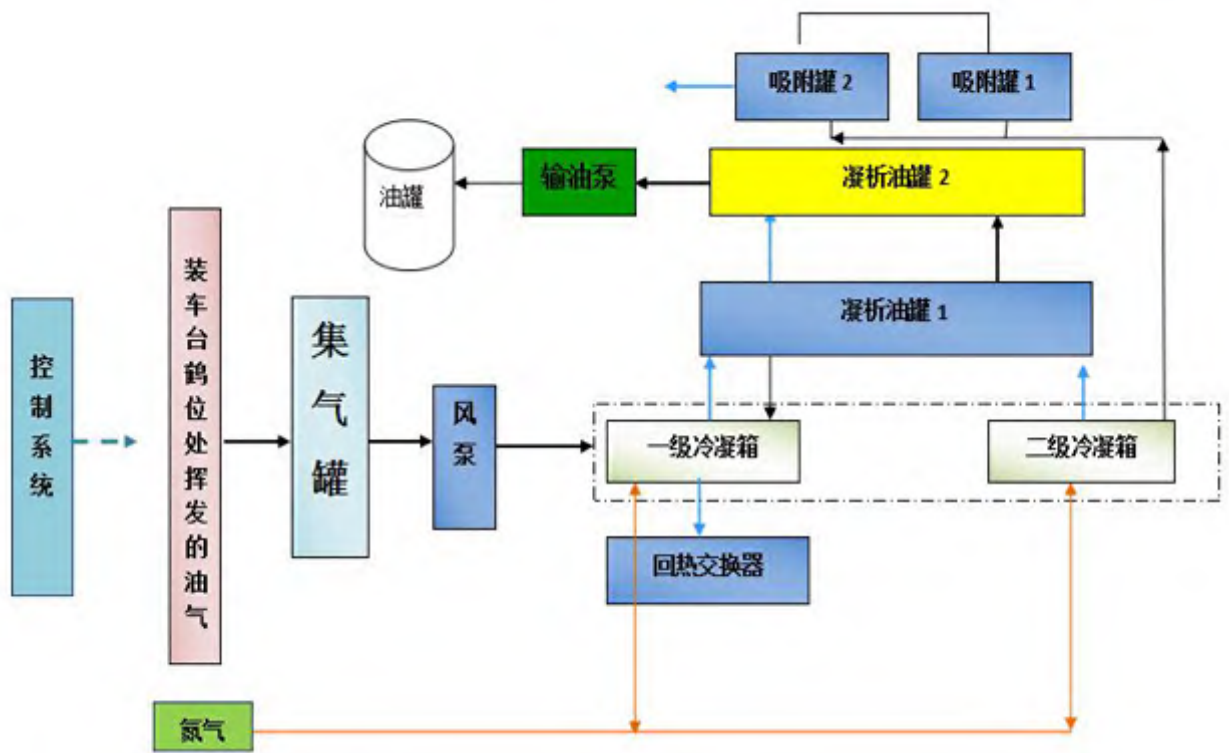

---

---



















---

---







---

---



---

---















### **3**

#### **3.1**

##### **3.1.1**

##### **3.1.2**











**3.1.3**

**3.1-3**



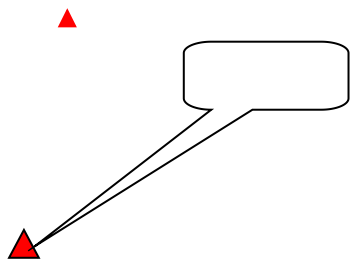

3-1

1:200000



3-2

1 9000

3.2

3.2-1

3.3

3.3.1



**3.3-2**

3.3-3

3.3-4

3.3-5



3.3-6

3.3.2

**3.3-7**

**3.4-1**

### 3.4.2

3.4-2

### 3.4.3

### 3.5





C4L8' μ Q H("p•







## 3.6

### 3.6.1



## 3.6.2









3.6.6

3.6.7

### 3.6.8

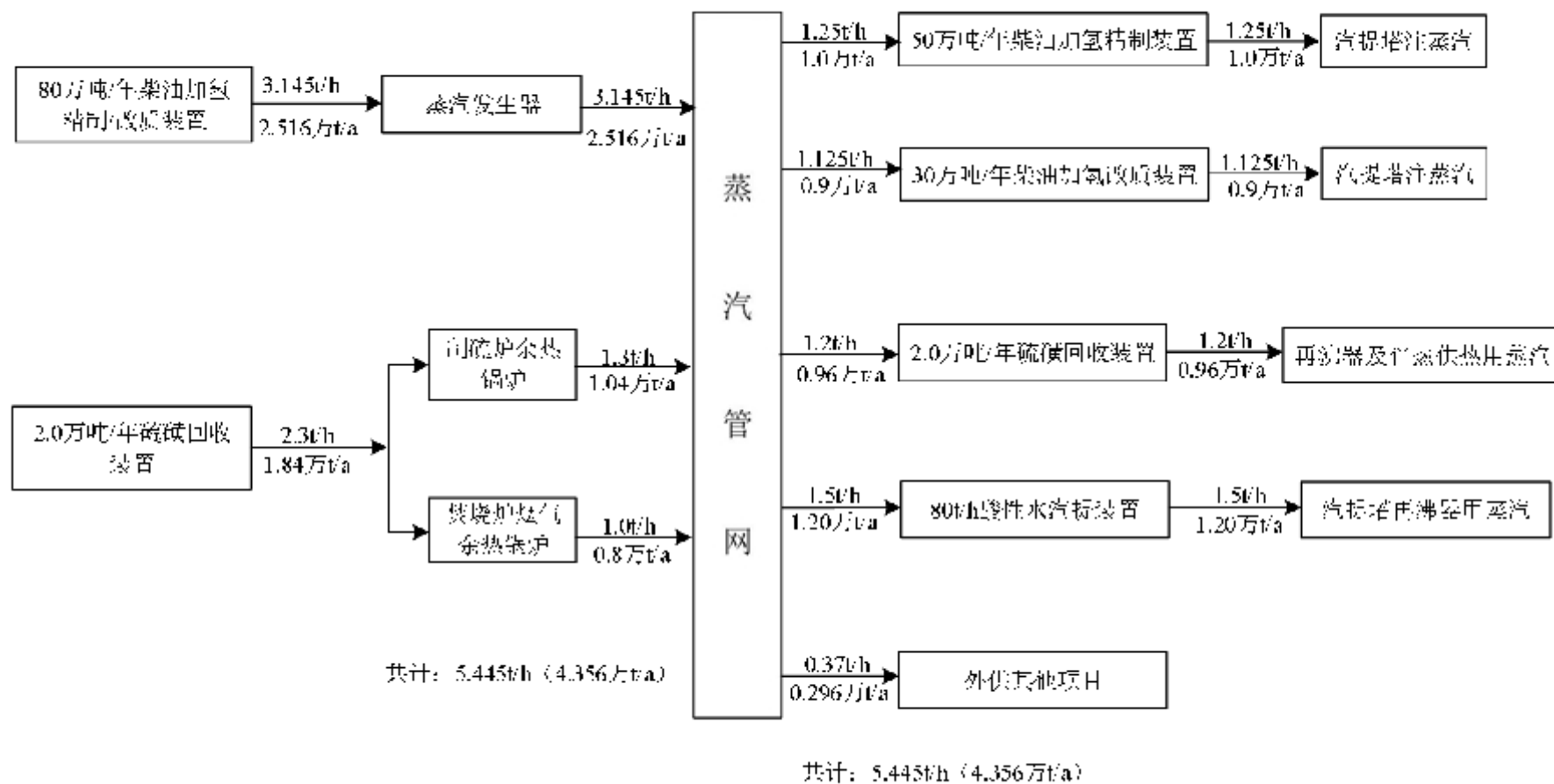
山东 化工 团 公司80万吨/年加 品  $\phi^{\prime\prime}\phi$



3.6-2

/ /

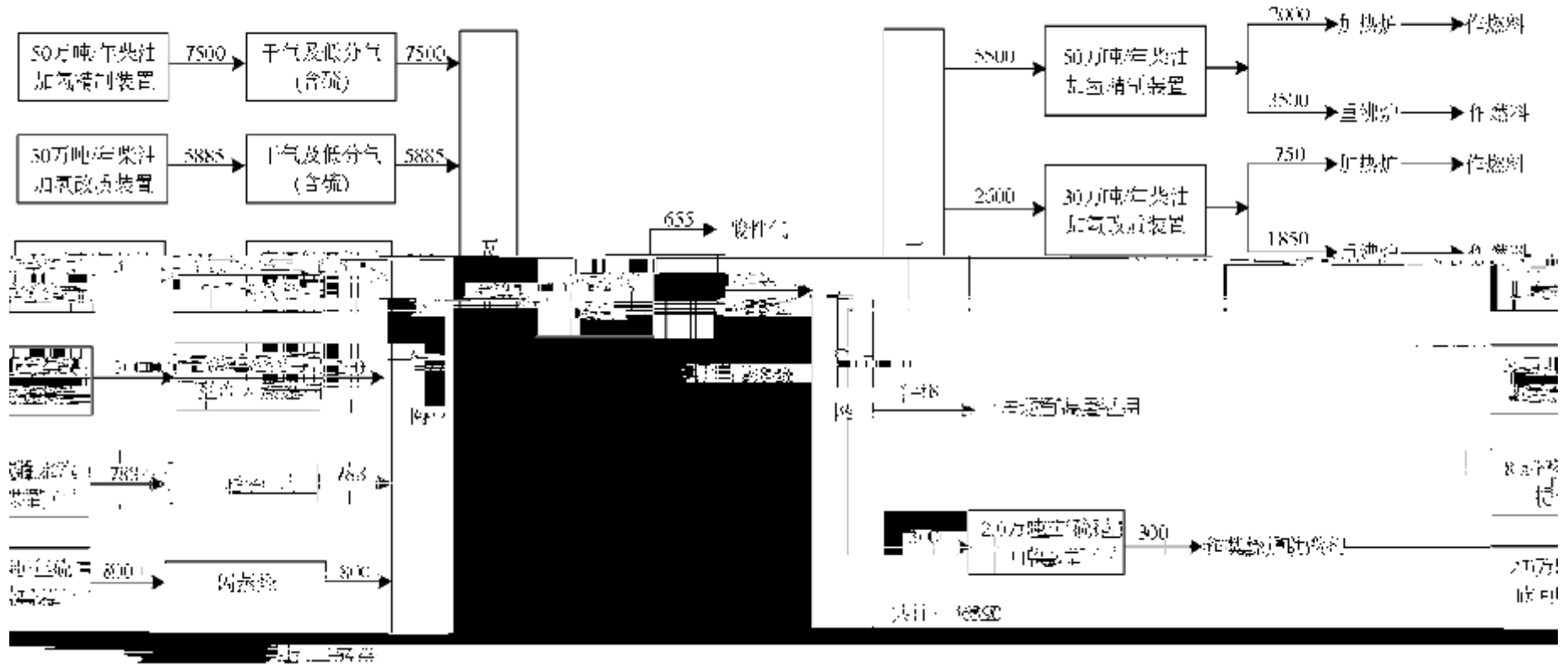

3.6-3

/

## **3.7**

### **3.7.1**

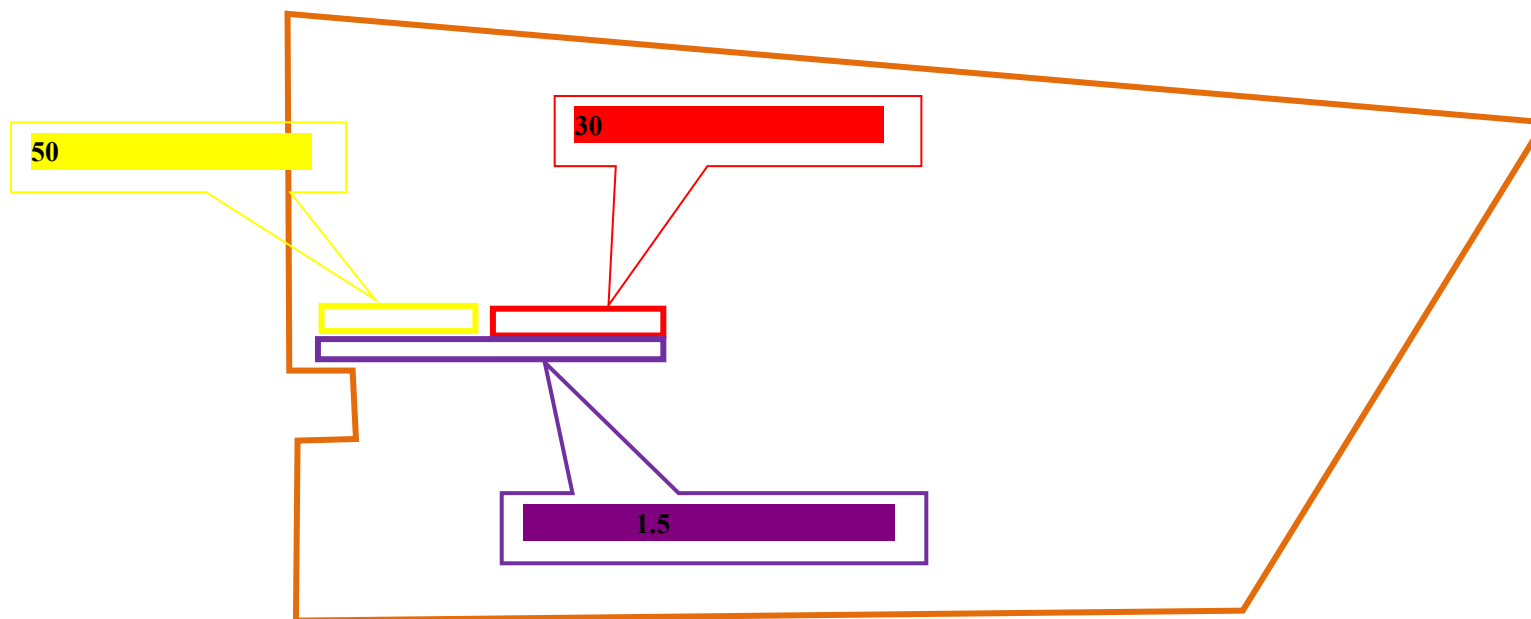
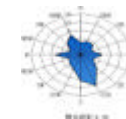

3.7-1

1 3000



### **3.7.2**

### **3.7.3**



1 50 /

→

→

→

→

→

→

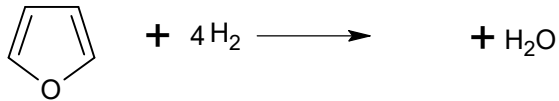
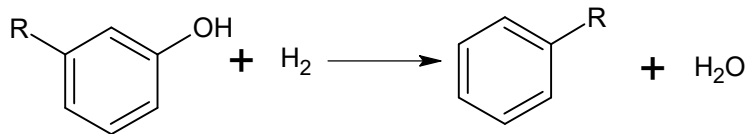
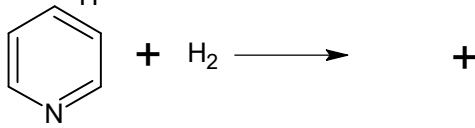
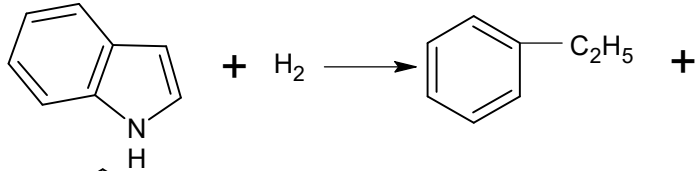
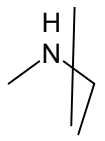

→

→







2 30 /

①

②

吡咯:

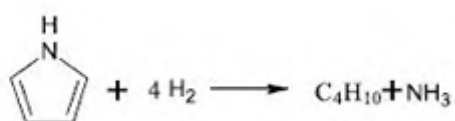

吲哚:

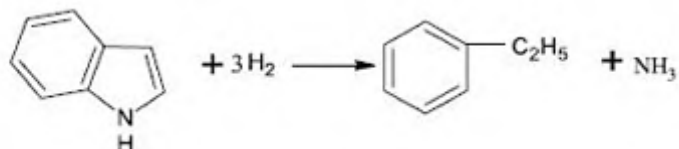

吡啶:

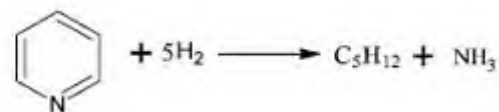

喹啉:



③加氢脱氧

酚类:

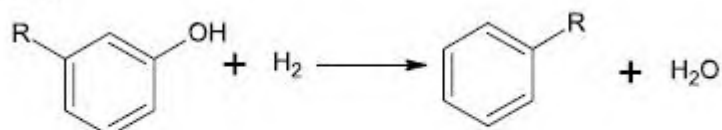

呋喃:

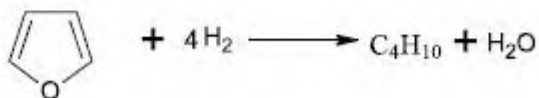

⑤芳烃加氢饱和

萘:

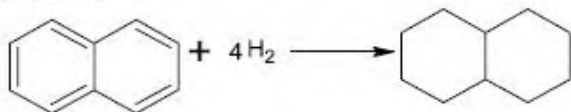

菲:

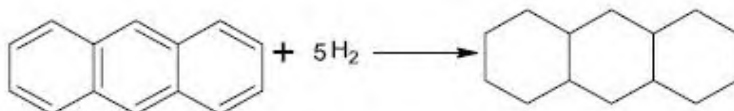





### 3.8.2

2 2.0 /

- - + = - -  
- - + = - -  
- - + + = - -  
- - + + = - -



3.8-4 2.0 /

3 40000 <sup>3/</sup>





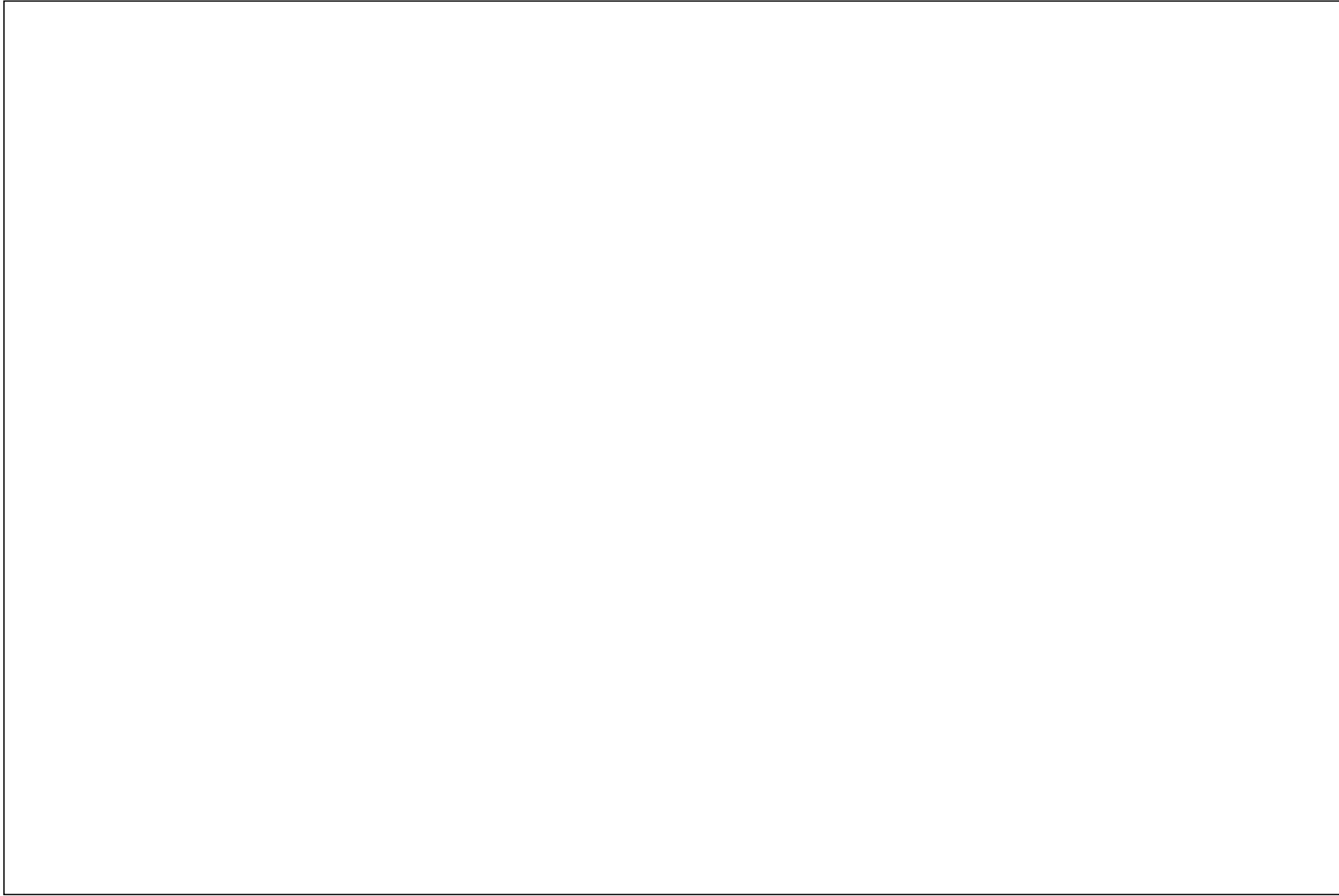

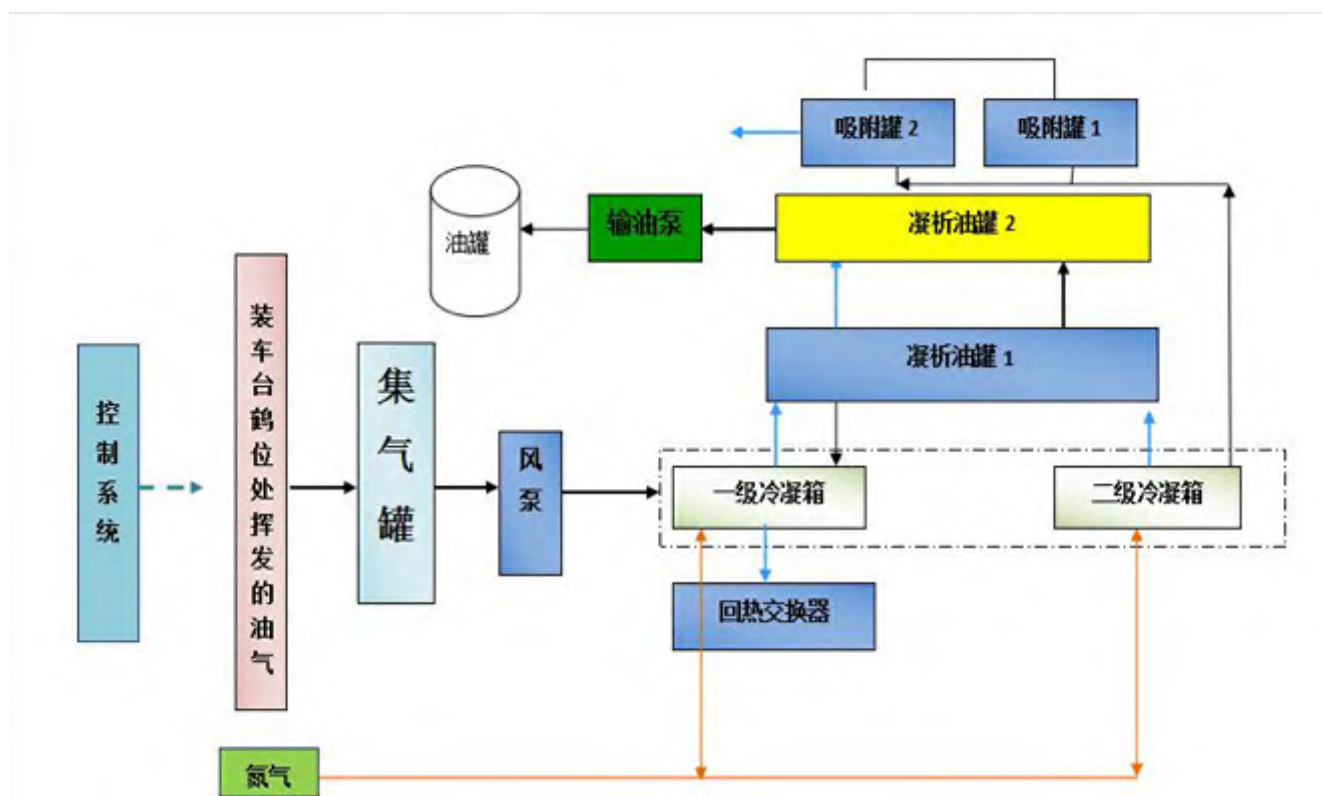

3.8-6







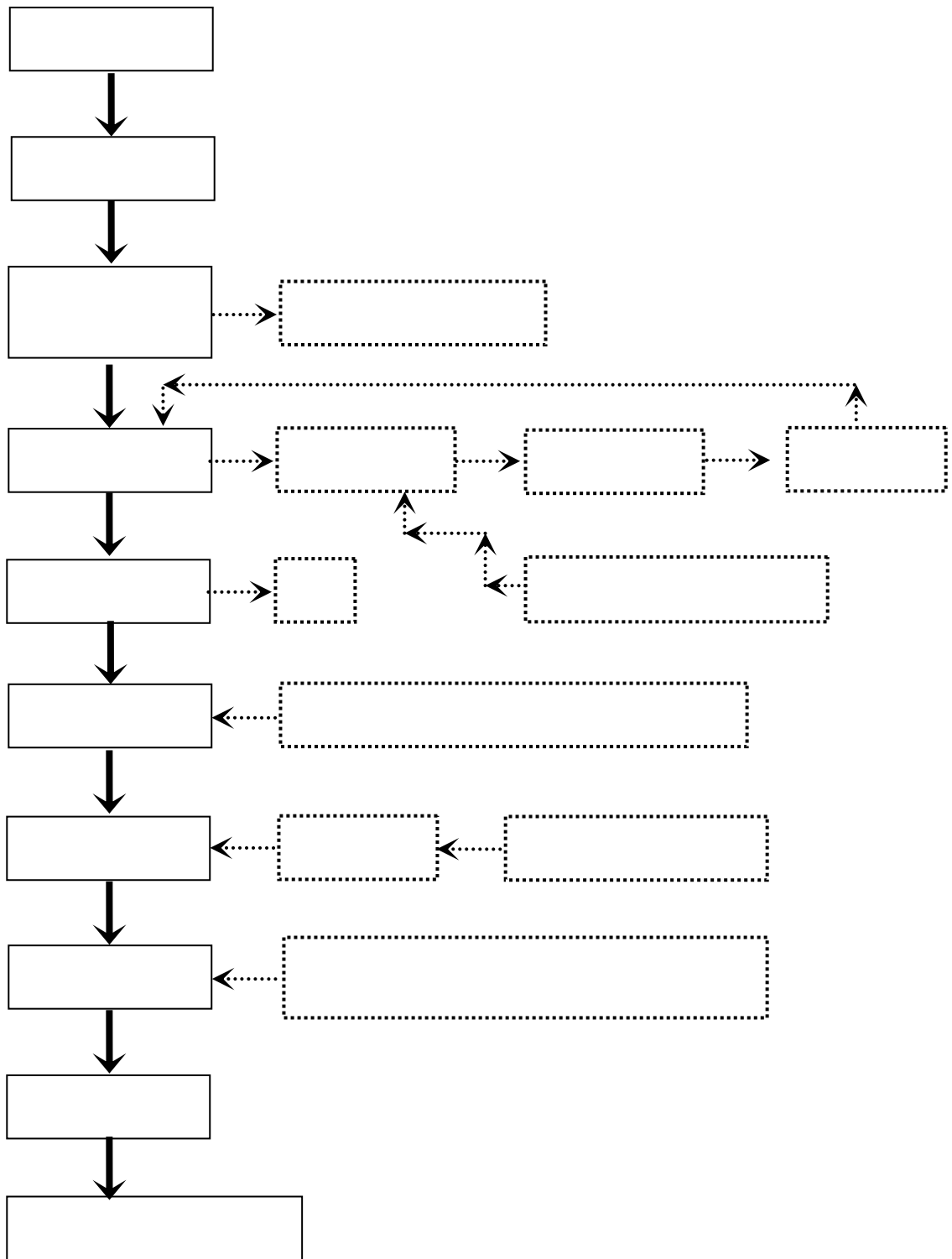

3.8-8

### 3.8.3

1

2

3















### 3.8.4

3.8-1 80 /





3.8-1

50 /

/

3.8-2

50 /

/



3.8-4

30 /

/

3.8-5

2.0 /

3.8-6

2.0 /

/

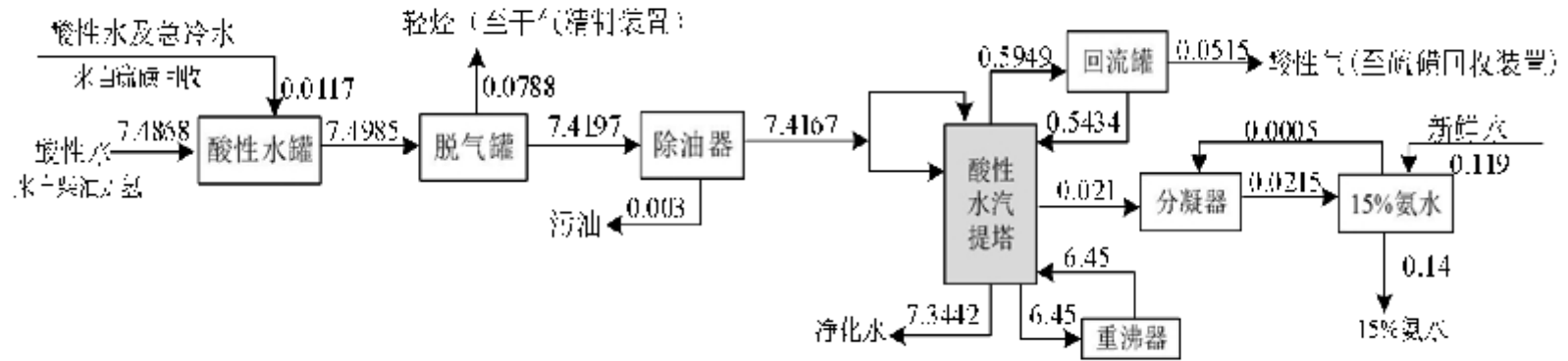

3.8-7

80 /

/

3.8-8

80 /

/



3.8-9

40000 <sup>3/</sup>

/

### 3.8.5

### 3.9

#### 3.9.1

##### 3.9.1.1

1 50 /

1

A019

1-1

1

3.9-1 50 /

		A019			
		2020.6.9			



2

! A019

4



#5 ь 5d1100@A•

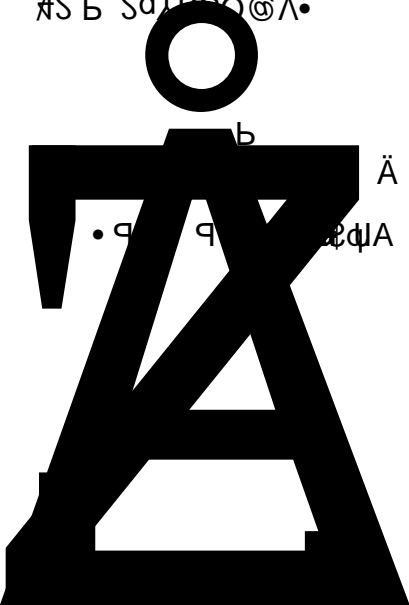

7



2

!  
A020







2

3.9-7 1.5 /

4

!

A002

4-1





5 40000 3/

1

A011

5-1

3.9-9

A011

		A011			
		2020.6.9			

2

A010

5-2

3.9-10

A010

		A010			
		2020.6.9			

6

A018

6-1

3.9-11

A018

		A018			
		2020.6.10			

7

!  
A024

7-1



## 3.9.1.2

1

1

$$E_{\text{设备}} = 0.003 \times \sum_{i=1}^n \left( e_{\text{TOC},i} \times \frac{WF_{\text{VOCs},i}}{WF_{\text{TOC},i}} \times t_i \right)$$

3.9-13

3.9-14

3.9-15

1

2

2

3.9-16

$$D_{\text{浮顶罐}} = E_R + E_{WD} \pm E_F + E_D$$

$$E_R = (K_{R\sigma} + K_{WRb} v^n) DP^* M_V K_C$$

$$P^* = \frac{\frac{P_{Vd}}{P_d}}{\left[1 + \left(1 - \frac{P_{Vd}}{P_d}\right)^{0.5}\right]^2}$$

$$E_{WD} = \frac{(0.943)QC_s W_L}{D} \left(1 + \frac{N_c F_c}{D}\right)$$

$$E_F = F_F P^* M_V K_C$$

$$F_F = [(N_{F1} K_{F1}) + (N_{F2} K_{F2}) + \dots + (N_{Fn} K_{Fn})]$$

$$K_{Fi} = K_{Fa_i} + K_{Fb_i} (K_v \nu)^{m_i}$$

$$K_{Fi} = K_{Fa_i}$$

$$L_D = K_D S_D D^2 P^* M_V K_C$$

3.9-17

3.9-18

3.9-20



3.9-21

3.9-22

3.9-23

3

3

$$E_{\text{装卸}} = \frac{L_L \times V}{1000} \times (1 - \eta_{\text{总}})$$

$$\eta_{\text{总}} = \eta_{\text{收集}} \times \eta_{\text{去除}} \times \eta_{\text{投用}}$$

□

b

3.9-26

4

5

$$E_{\text{设备}} = 0.003 \times \sum_{i=1}^n \left( e_{\text{TOC},i} \times \frac{WF_{\text{VOCs},i}}{WF_{\text{TOC},i}} \times t_i \right)$$

3.9-27

5

6

6

$$E_{\text{设备}} = 0.003 \times \sum_{i=1}^n \left( e_{\text{TOC},i} \times \frac{WF_{\text{VOCs},i}}{WF_{\text{TOC},i}} \times t_i \right)$$

3.9-28

6

7

7

8

8



## 3.9.2

3.9-30



				/		/	/	/	/						



### 3.9.3

1











山东

四

司80万

品

升

改

分

2



3.9-33

### 3.9.3

1 50 /

2 30 /

3

4

5









### 3.9.4

3.9-35

### 3.10

3.10-1

		/	/	/





## **3.11**

### **3.11.1**

### **3.11.2**

### **3.11.3**



### 3.12

### 3.13







273 578

87.1%

2

66051.8

2.1%

3

12581.3

0.4%

4

327113.8

10.4%

2

18306-2001

1

18306-2001

1

0.05

0.45

### 4.1.3

#### 4.1.3.1

100<sup>2</sup>

26

10

20

$3.25 \cdot 10^8 \cdot 3$



500

17

50.6

16

1 1

3.8<sup>2</sup>

3.37<sup>2</sup>

10.4

2082 10<sup>4 3</sup>

6.24

17 10<sup>4 3</sup>/

18 2000 12

7671.7 11.5

3341 10<sup>4 3</sup>

6-1



6-1

4.1.3.2



0.1

0.5 1.0

2.5 3.0

10 /

-

### 4.1.4

11.7

3 .6

-18.0

54

67%

8.1%

7.5%

3.4 /

5

6.3

2.

35.6

12

8.5

11

7

1.3

50

2.1

2728.5

5

284.

12

183.0 1

-2.8 7

26.7

2 .5

613.6

424.8

16.2

1142.6

244.5

12.0

1 26.0

3.3 /

14.6

64

0.5



### 4.1.5

0.5

2.0

50021-2001

200

4

-

1.40

3.30

4

1.40

3.30

2.40

4.20

4

-

4.80

7.00

2.60

4.00

4

-

8.00

10.40

1.60

2.70



4 -

10.30

12.70 7.60 10.20

4

-

12.50 15.60

3.40

4

1 .10 22. 0 1.40 4.10

4

21.70 24.80

1.80 4.80

4 -

23.00 25.40 1.80

4 -

25.00 27. 0 4.80 8.20

4 -

26.30 33.40

1. 0

4

31.10 34.30 35

10 / -



### 4.1.6

1

4%

0.6%

5 %

36%

( )

0.2%

2

4.3%

5.7%

40

110

160

3



150

50

### 4.1.7

18306-2015

0.05

0.45

### 4.2

1 83 10

1188.4

200.48

1 84

1156.62

5

58

40

44

66

15

2005

84

14 3

4642

22

2005

31



5

7

5

35

80

0

12

438

3000-4000

1.5-1

### 4.3

1.5-2

1.5-1



### 4.4

#### 4.4.4

##### 4.4.1.1

1

2018

4.4-1

2018

			/ 3	/ 3	%	
	2		1	60	31.7	
		8	46	150	30.7	
	2		35	40	87.5	
		8	76	80	5	
	10		105	70	150	
		5	207	150	138	
	2.5		4	35	140	
		5	111	75	148	
		5	1500	4000	35.0	
	3	0 8	202	160	126	

2018

10

2.5 3

30 5-2012 2018

2

2018-2020

2018

2020

2015

35

46

/

85

/

65%

2015

50%

15



4.4.1.2

1

2018

1

663

4.4-2

4.4-2

2018

						/ 3		/ 3	
								%	
	118.487	37.458	2			1	60	31.7	
				8	46	150	30.7		
			2			35	40	87.5	
				8	76	80	5		
			10			105	70	150	
				5	207	150	138		
			2.5			4	35	140	
				5	111	75	148		
					5	1500	4000	35.0	
			3	0	8	202	160	75.6	

2018

2 2

24

24

30 5-2012

10 2.5

24

3

8



2

7

1

2

4.4-3

4-3

4.4-3

			<b>m</b>	
1#	1500		1500	
2#		--	--	

2

2020

8

23

2020

8

2

7

2020

721

7

4

2 00

8 00

14 00

20 00

1





	604-2017	-	0.07 / 3
	/ 33-1		2 / 3
	584-2010	/	1.5 10 <sup>-3</sup> / 3
	584-2010	/	1.5 10 <sup>-3</sup> / 3
	584-2010	/	1.5 10 <sup>-3</sup> / 3
	/ 15432-1 5		0.001 / 3

4

4.4-5

4.4-6

4.4-5

气象条件		( )	(kPa)	(m/)	/
日期	时间				
2020.08.23	08 00	31	100.2	1.2	3/2
	14 00	28	100.1	1.3	2/1
	17 00	24	100.3	1.0	1/0
2020.08.24	08 00	2	100.1	1.3	2/1
	14 00	31	101.0	1.2	1/0
	17 00	24	100.3	1.0	1/0
2020.08.25	08 00	2	100.2	1.5	3/1
	14 00	33	100.1	1.3	2/1
	17 00	27	100.3	1.4	1/0
2020.08.26	08 00	27	100.2	1.5	2/1
	14 00	30	100.7	1.7	0/0
	17 00	2	101.0	1.3	1/0
2020.08.27	08 00	27	100.2	1.7	0/0
	14 00	30	100.4	1.1	1/0
	17 00	2	100.7	1.3	1/1
2020.08.28	08 00	27	101.2	1.5	2/1
	14 00	31	100.3	1.4	1/1
	17 00	28	100.7	1.0	0/0
2020.08.2	08 00	28	100.2	1.4	0/0
	14 00	30	100.1	1.3	1/0
	17 00	27	100.1	1.7	2/0



## 4.4-6 1

		mg/m <sup>3</sup>	
		1#	1500m
2020.08.23	02 00	0.08	0.07
	08 00	0.07	0.06
	14 00	0.06	0.0
	20 00	0.08	0.05
2020.08.24	02 00	0.07	0.08
	08 00	0.08	0.07
	14 00	0.06	0.0
	20 00	0.07	0.06
2020.08.25	02 00	0.08	0.05
	08 00	0.08	0.06
	14 00	0.0	0.08
	20 00	0.07	0.06
2020.08.26	02 00	0.08	0.07
	08 00	0.06	0.06
	14 00	0.07	0.07
	20 00	0.05	0.08
2020.08.27	02 00	0.08	0.07
	08 00	0.0	0.05
	14 00	0.08	0.06
	20 00	0.06	0.08
2020.08.28	02 00	0.06	0.06
	08 00	0.08	0.05
	14 00	0.0	0.06
	20 00	0.05	0.07
2020.08.2	02 00	0.08	0.06
	08 00	0.08	0.05
	14 00	0.07	0.07
	20 00	0.06	0.07



4.4-6 2

		/ 3		
		1#	1500	2#
2020.08.23	02 00			
	08 00			
	14 00			
	20 00			
2020.08.24	02 00			
	08 00			
	14 00			
	20 00			
2020.08.25	02 00			
	08 00			
	14 00			
	20 00			
2020.08.26	02 00			
	08 00			
	14 00			
	20 00			
2020.08.27	02 00			
	08 00			
	14 00			
	20 00			
2020.08.28	02 00			
	08 00			
	14 00			
	20 00			
2020.08.2	02 00			
	08 00			
	14 00			
	20 00			



---

---

**4.4-6 3**

1#



## 4.4-6 4

		VOCs		mg/m <sup>3</sup>
		1#	1500m	2#
2020.08.23	02 00	0. 8		0. 7
	08 00	1.04		0.81
	14 00	0.7		1.11
	20 00	1.0		1.01
2020.08.24	02 00	1.02		0. 4
	08 00	0. 2		1.07
	14 00	1.20		0. 7
	20 00	0. 5		1.05
2020.08.25	02 00	0. 4		0. 6
	08 00	1.0		1.18
	14 00	1.18		1.03
	20 00	1.00		1.24
2020.08.26	02 00	0. 0		0. 3
	08 00	0.		1.05
	14 00	1.12		1.1
	20 00	1.01		1.01
2020.08.27	02 00	0. 7		1.01
	08 00	1.07		0. 6
	14 00	1.03		1.16
	20 00	0. 8		0. 3
2020.08.28	02 00	0. 2		1.02
	08 00	1.07		0. 7
	14 00	0. 5		1.12
	20 00	1.16		1.00
2020.08.2	02 00	1.04		1.01
	08 00	1.07		1.00
	14 00	0. 8		1.07
	20 00	1.11		0. 4



## 4.4-6 5

		mg/m <sup>3</sup>		
		1#	1500m	2#
2020.08.23	02 00			
	08 00			
	14 00			
	20 00			
2020.08.24	02 00			
	08 00			
	14 00			
	20 00			
2020.08.25	02 00			
	08 00			
	14 00			
	20 00			
2020.08.26	02 00			
	08 00			
	14 00			
	20 00			
2020.08.27	02 00			
	08 00			
	14 00			
	20 00			
2020.08.28	02 00			
	08 00			
	14 00			
	20 00			
2020.08.2	02 00			
	08 00			
	14 00			
	20 00			



## 4.4-6 6

		mg/m <sup>3</sup>		
		1#	1500m	2#
2020.08.23	02 00			
	08 00			
	14 00			
	20 00			
2020.08.24	02 00			
	08 00			
	14 00			
	20 00			
2020.08.25	02 00			
	08 00			
	14 00			
	20 00			
2020.08.26	02 00			
	08 00			
	14 00			
	20 00			
2020.08.27	02 00			
	08 00			
	14 00			
	20 00			
2020.08.28	02 00			
	08 00			
	14 00			
	20 00			
2020.08.2	02 00			
	08 00			
	14 00			
	20 00			



## 4.4-6 7

		mg/m <sup>3</sup>		
		1#	1500m	2#
2020.08.23	02 00			
	08 00			
	14 00			
	20 00			
2020.08.24	02 00			
	08 00			
	14 00			
	20 00			
2020.08.25	02 00			
	08 00			
	14 00			
	20 00			
2020.08.26	02 00			
	08 00			
	14 00			
	20 00			
2020.08.27	02 00			
	08 00			
	14 00			
	20 00			
2020.08.28	02 00			
	08 00			
	14 00			
	20 00			
2020.08.2	02 00			
	08 00			
	14 00			
	20 00			



## 4.4-6 8

		mg/m <sup>3</sup>		
		1#	1500m	2#
2020.08.23	02 00			
	08 00			
	14 00			
	20 00			
2020.08.24	02 00			
	08 00			
	14 00			
	20 00			
2020.08.25	02 00			
	08 00			
	14 00			
	20 00			
2020.08.26	02 00			
	08 00			
	14 00			
	20 00			
2020.08.27	02 00			
	08 00			
	14 00			
	20 00			
2020.08.28	02 00			
	08 00			
	14 00			
	20 00			
2020.08.2	02 00			
	08 00			
	14 00			
	20 00			



4.4-6 9

	TSP mg/m <sup>3</sup>		
	1#	1500m	2#
2020.08.23	0.18		0.237
2020.08.24	0.13		0.215
2020.08.25	0.210		0.242
2020.08.26	0.204		0.228
2020.08.27	0.207		0.235
2020.08.28	0.212		0.240
2020.08.2	0.16		0.20

5

1

$P_i C_i/C_{oi}$

$C_i$

/ <sup>3</sup>

$C_{oi}$

/ <sup>3</sup>

$P_i$

2

2.2-2018

4.4-7

4.4-7

mg/m<sup>3</sup>

1			/ <sup>3</sup>	200	
2			/ <sup>3</sup>	3000	2.2-2018
3			/ <sup>3</sup>	200	
4			/ <sup>3</sup>	110	
5			/ <sup>3</sup>	200	
6			/ <sup>3</sup>	10	
7			/ <sup>3</sup>	200	
8			/ <sup>3</sup>	300	30 5-2012

3

4.4-8



4.4-8

		/ 3	/ 3	%	%
1		3000	1.0	33	0

1#  
1500      -1461      1161



### 4.4.1.3

$$C_{\text{现状}(x,y)} = \text{MAX} \left[ \frac{1}{n} \sum_{j=1}^n C_{\text{监测}(j,t)} \right]$$

(,) (,) / 3

(,) 1 8

/ 3

4.4-

4.4-9

			/ 3
1		1	1.0
2		1	7.5 10 <sup>-4</sup>
3		1	7.5 10 <sup>-4</sup>
4		1	7.5 10 <sup>-4</sup>
5		1	0.085
6		1	0.0005
7		1	1.16
8			0.216

### 4.4.2

#### 4.4.2.1

1

2020 8 23 8 25

2020 721

500

500

500

500

5

4-4

4.4-10

1#	500	
2#		
3#	500	
4#	500	
5#	500	



4-4

1:30000

4-28



2

5

30

3

3

3838-2002

4.4-11

	6 20-1 86		
	828-2017		4 /
5	505-200	5	0.5 /
	11 01-1 8		
	535-200		0.025 /
	118 3-1 8		0.01 /
	636-2012		0.05 /
	70-2018		0.01 /
	118 -8		10 /
	118 6-1 8		10 /
	484-200	-	0.004 /
	/ 1648 -1 6		0.005 /
	/ 7484-1 87		0.05 /
	503-200	4-	0.01 /
	347.2-2018		20 /
	/ 51-1		10 /
	74 4-1 87		0.05 /



	6 4-2014		0.04 /
	700-2014	65	0.12 /
	700-2014	65	0.0 /
	700-2014	65	0.05 /
	700-2014	65	0.08 /
	700-2014	65	0.06 /
	700-2014	65	0.67 /
	700-2014	65	0.41 /
	/ 7467-1 87		0.004 /
	1067-201	/	2 /
	1067-201	/	2 /
	1067-201	/	2 /
	1067-201	/	2 /
	1067-201	/	2 /

4

4.4-12

4.4-12a

		500m						500m		
		8.23	8.24	8.25	8.23	8.24	8.25	8.23	8.24	8.25
		7.30	7.32	7.2	7.26	7.28	7.25	7.31	7.33	7.2
	/	32	2	30	26	2	28	27	27	25
5	/	7.8	7.4	7.6	7.2	7.8	7.4	7.4	7.6	7.0
	/	11	12	10	14	11	13	12	14	11
	/	0.417	0.568	0.521	0.451	0.545	0.504	0.486	0.53	0.545
	/	0.2	0.25	0.27	0.1	0.24	0.22	0.26	0.23	0.25
	/	6.05	6.18	6.23	3.86	3.7	3.5	3.8	4.01	3.6
	/									
	/	187	181	185	175	176	172	205	207	210
	/	552	538	543	518	522	514	606	611	60
	/									



/										
/	0.5	0.61	0.61	0.64	0.64	0.64	0.67	0.67	0.67	
/										
/	360	320	340	260	330	270	440	380	430	
/	1.05 10 <sup>3</sup>	1.03 10 <sup>3</sup>	1.06 10 <sup>3</sup>	65	85	72	1.12 10 <sup>3</sup>	1.14 10 <sup>3</sup>	1.11 10 <sup>3</sup>	
/										
/										
/	1.	2.35	2.31	1.06	1.08	1.15	3.52	13.5	8.27	
/	1.1	1.37	1.3	1.24	1.21	1.1	1.20	1.33	1.24	
/	0.06	0.05	0.05	0.08	0.05	0.06	0.16	0.18	0.18	
/	12.4	13.2	12.0	13.1	12.4	11.4	18.1	28.	22.4	
/	3.83	3.70	3.71	4.30	4.04	4.10	4.56	4.72	4.5	
/										
/	10.7	.	12.0	10.3	10.8	10.1	11.7	12.8	12.3	
/										
/										
/										
/										
/										
/										
/										
		27.0	26.8	27.0	26.	26.6	26.8	27.1	27.0	27.2
		5.1			6.2			6.2		
		1.1			0.7			0.8		
/		0.8			0.			1.0		
<sup>3/</sup>		3.37			2. 3			3.72		

4.4-12b

		500m			500m		
		8.23	8.24	8.25	8.23	8.24	8.25
		7.25	7.2	7.30	7.33	7.31	7.28
/		2	23	26	24	2	27



5	/	7.8	6.8	7.2	6.8	7.6	7.4
	/	45	50	46	18	16	20
	/	0.754	0.725	0.71	1.21	1.24	1.20
	/	0.2	0.24	0.26	0.22	0.26	0.25
	/	6.8	7.13	7.05	4.82	4.3	4.72
	/						
	/	231	235	240	233	237	22
	/	685	65	68	60	680	683
	/						
	/						
	/	0.56	0.54	0.54	1.80	1.6	1.76
	/						
	/	450	460	430	400	40	460
	/	1.02 10 <sup>3</sup>	1.00 10 <sup>3</sup>	1.03 10 <sup>3</sup>	1.18 10 <sup>3</sup>	1.16 10 <sup>3</sup>	1.15 10 <sup>3</sup>
	/						
	/						
	/	3.5	4.17	5.8	3.08	1.56	1.42
	/	1.12	1.26	1.02	1.14	0.	1.10
	/	0.12	0.13	0.20	0.07	0.07	0.07
	/	13.6	13.3	14.4	16.8	18.0	12.8
	/	4.71	4.58	4.64	4.8	4.47	4.40
	/	5.77	2.1	2.05	1.14	1.51	
	/	10.2	8.06	7.8	8.53	.16	10.3
	/						
	/						
	/						
	/						
	/						
	/						

东	80万 /		书	04	与	
	26.8	26.	26.7	27.2	27.3	27.1
		6.0			4.2	
		1.0			1.0	
/		1.2			1.1	
<sup>3</sup> /		5.40			3.46	



$$P_{pH} = \frac{7.0 - pH_{C_i}}{7.0 - pH_{sd}} \quad 7.0 \quad P_{pH} = \frac{pH_{C_i} - 7.0}{pH_{su} - 7.0} \quad 7.0$$

$$S_{DO} = \frac{|DO_f - DO_j|}{DO_f - DO_s} \quad S_{DO} = 10 - \frac{DO_j}{DO_s}$$

$$f=468/ \quad 31.6+$$

3

4.4-13

			5									
1#	8.23	0.205	0.78	0.80	0.21	3.03	0.73	0.75			0.006	2.21
	8.24	0.1 5	0.74	0.73	0.28	3.0	0.63	0.73			0.005	2.15
	8.25	0.202	0.76	0.75	0.26	3.11	0.68	0.74			0.005	2.17
2#	8.23	0.24	0.72	0.65	0.28	1. 3	0.48	0.70			0.008	2.07
	8.24	0.225	0.78	0.73	0.27	1.80	0.60	0.70			0.005	2.08
	8.25	0.23	0.74	0.70	0.25	1. 7	0.55	0.6			0.006	2.06
3#	8.23	0.425	0.74	0.68	0.24	1. 4	0.65	0.82			0.016	2.43
	8.24	0.41	0.76	0.68	0.27	2.00	0.58	0.83			0.018	2.45
	8.25	0.435	0.70	0.63	0.27	2.00	0.63	0.84			0.018	2.74
4#	8.23	0.202	0.78	0.73	0.37	3.4	0.73	0. 2			0.012	2.78
	8.24	0.24	0.68	0.58	0.37	3.57	0.60	0. 4			0.013	2.76
	8.25	0.225	0.72	0.65	0.36	3.50	0.65	0. 6			0.020	2.76
5#	8.23	0.23	0.68	0.60	0.61	2.41	0.55	0. 3			0.007	2.77
	8.24	0.425	0.76	0.73	0.62	2.47	0.65	0. 5			0.007	2.72
	8.25	0.41	0.74	0.68	0.62	2.36	0.63	0. 2			0.007	2.73
1#	8.23		0.3	1.05					0.01	0.011		
	8.24		0.41	1.03					0.0235	0.0137		
	8.25		0.41	1.06					0.0231	0.013		
2#	8.23		0.43	0. 65					0.0106	0.0124		
	8.24		0.43	0. 85					0.0108	0.0121		
	8.25		0.43	0. 72					0.0115	0.011		
3#	8.23		0.45	1.12					0.0352	0.0120		
	8.24		0.45	1.14					0.135	0.0133		
	8.25		0.45	1.11					0.0827	0.0124		



4#	8.23		0.37	1.02					0.035	0.0112	0.28		
	8.24		0.36	1.00					0.0417	0.0126	0.146		
	8.25		0.36	1.03					0.5 8	0.0102	0.103		
5#	8.23		1.20	1.18					0.308	0.0114	0.057		
	8.24		1.13	1.16					0.156	0.00	0.076		
	8.25		1.17	1.15					0.142	0.0110			

3.57 1.18 2.78 5#

1.20

3838-2002



### 4.4.3

#### 4.4.3.1

( 610-2016)

84

4.4-14

	85	( 610-2016)

1

610-2016

5

10

4.4-15

4-5

4.4-15

			m	
1#			30	
2#	500		500	
3#	600		600	
4#	200		200	
5#	450		450	
6#	300		300	
7#	350		350	
8#	500		500	
#	400		400	
10#	300		300	



2

2

+ + 2+ + 3<sup>2-</sup> 3<sup>-</sup>

- 4<sup>2-</sup> 32

3

2020 8 23 1 1

2020 721



6-4

1:8000

4-3



4

## 4.4-16a

	/ 5750.4-2006		
	/ 5750.5-2006		0.02 /
	/ 5750.7-2006		0.05 /
	/ 5750.4-2006		10 /
	/ 5750.4-2006		1.0 /
	/ 5750.5-2006	2.1	0.15 /
	/ 5750.5-2006	1.5	10 /
	/ 5750.5-2006		0.2 /
	/ 5750.5-2006		0.001 /
	/ 5750.4-2006	.14-	0.001 /
	/ 5750.5-2006		0.2 /
	/ 5750.6-2006		1.0 /
	/ 5750.6-2006		0.1 /
	/ 5750.6-2006	10.1	0.004 /
	700-2014	65	0.0 /
	700-2014	65	0.05 /
	700-2014	65	0.08 /
	700-2014	65	0.67 /
	700-2014	65	0.82 /
	700-2014	65	0.12 /
	/ 5750.12-2006		2 /100
	70-2018		0.01 /



	/ 5750.5-2006	-	0.002 /
	/ 1648 -1 6		0.005 /
+	812-2016		0.02 /
+	812-2016		0.02 /
2+	812-2016		0.03 /
2+	812-2016		0.02 /
-	84-2016	$4^{3-}$ $3^{2-}$ $4^{2-}$ $2^-$ $3^-$	0.007 /
$4^{2-}$	84-2016	$4^{3-}$ $3^{2-}$ $4^{2-}$ $2^-$ $3^-$	0.018 /
$3^{2-}$	/ 0064.4 -1 3		5 /
$3^-$	/ 0064.4 -1 3		5 /

#### 4.4-16b

	/ 5750.4-2006		
	/ 5750.5-2006		0.02 /
	/ 5750.7-2006		0.05 /
	/ 5750.4-2006		10 /
	/ 5750.4-2006		1.0 /
	/ 5750.5-2006	2.1	0.15 /
	/ 5750.5-2006	1.5	10 /
	/ 5750.5-2006		0.2 /
	/ 5750.5-2006		0.001 /
	/ 5750.4-2006	.1 4-	0.001 /
	/ 5750.5-2006		0.2 /
	/ 5750.6-2006		1.0 /



	/ 5750.6-2006		0.1 /
	/ 5750.6-2006	10.1	0.004 /
	700-2014	65	0.0 /
	700-2014	65	0.05 /
	700-2014	65	0.08 /
	700-2014	65	0.67 /
	700-2014	65	0.82 /
	700-2014	65	0.12 /
	/ 5750.12-2006		2 /100
	70-2018		0.01 /
	/ 5750.5-2006	-	0.002 /
	/ 1648 -1 6		0.005 /
+	812-2016		0.02 /
+	812-2016		0.02 /
2+	812-2016		0.03 /
2+	812-2016		0.02 /
-	84-2016	4 <sup>3-</sup> 3 <sup>2-</sup> 4 <sup>2-</sup> 2 <sup>-</sup> 3 <sup>-</sup>	0.007 /
4 <sup>2-</sup>	84-2016	4 <sup>3-</sup> 3 <sup>2-</sup> 4 <sup>2-</sup> 2 <sup>-</sup> 3 <sup>-</sup>	0.018 /
3 <sup>2-</sup>	/ 0064.4 -1 3		5 /
3 <sup>-</sup>	/ 0064.4 -1 3		5 /

5

4.4-17

4.4-17a

		SW500m	NE600m	NW200m
				SE450m



		6.45	6.30	6.21	6.2	6.41
	/	1.03	1.6	0.53	0.82	2.4
	/	6.27	13.33	14.12	.02	12.53
	/	1.30 10 <sup>3</sup>	5.40 10 <sup>3</sup>	4.80 10 <sup>3</sup>	3.1 10 <sup>3</sup>	7.40 10 <sup>3</sup>
	/	320.7	2.2 10 <sup>3</sup>	2.07 10 <sup>3</sup>	1.33 10 <sup>3</sup>	3.12 10 <sup>3</sup>
	/	260	2.37 10 <sup>3</sup>	1.7 10 <sup>3</sup>	1.21 10 <sup>3</sup>	3.17 10 <sup>3</sup>
	/	210	475	670	378	650
	/	0.3	0.	1.2	1.8	1.0
	/	0.102	0.003	0.126	0.124	0.015
	/					
	/	0.6	0.7	0.4	0.7	0.6
	/	0.3	1.28	2.04	1.04	0.0
	/					
	/					
	/	1.41		3.17	1.37	1.08
	/	4.62	430	278	427	688
	/	58.3	240	521	215	316
	/	0.3	1.28	2.04	1.04	0.0
	/	0.30	0.10	0.61	0.8	0.62
	/	2.08	7.81	10.5	12.6	12.0
	/	1.00	3.23	3.15	3.8	3.84
	/100					
	/					
	/					
	/					
+	/	4.62	.2	6.60	4.82	11.0
+	/	2.8	1.32 10 <sup>3</sup>	1.08 10 <sup>3</sup>	702	1.81 10 <sup>3</sup>
2+	/	43.5	252	236	188	28



2+	/	48.6	3 8	358	201	576																																			
-	/	246	2.34 10 <sup>3</sup>	1.81 10 <sup>3</sup>	1.18 10 <sup>3</sup>	3.1 10 <sup>3</sup>																																			
4 <sup>2-</sup>	/	205	403	651	355	624																																			
3 <sup>2-</sup>	/																																								
3 <sup>-</sup>	/	424	641	51	506	848																																			
		200		7	7	7																																			
		4.7	4.5	4.2	4.2	4.1																																			
		26.5	13.2	12.8	12.7	12.8																																			
<table border="1" style="width: 100%; border-collapse: collapse;"> <tr> <td></td> <td></td> <td></td> <td></td> <td></td> <td></td> <td></td> </tr> <tr> <td></td> <td></td> <td style="text-align: center;"><b>SW300m</b></td> <td style="text-align: center;"><b>S350m</b></td> <td style="text-align: center;"><b>NW500m</b></td> <td style="text-align: center;"><b>NE400m</b></td> <td style="text-align: center;"><b>W300m</b></td> </tr> <tr> <td></td> <td></td> <td style="text-align: center;">8</td> <td style="text-align: center;">10</td> <td style="text-align: center;">7</td> <td style="text-align: center;">8</td> <td style="text-align: center;">7</td> </tr> <tr> <td></td> <td></td> <td style="text-align: center;">4.3</td> <td style="text-align: center;">4.7</td> <td style="text-align: center;">4.0</td> <td style="text-align: center;">4.2</td> <td style="text-align: center;">4.1</td> </tr> <tr> <td></td> <td></td> <td style="text-align: center;">12.8</td> <td style="text-align: center;">13.5</td> <td style="text-align: center;">12.7</td> <td style="text-align: center;">12.</td> <td style="text-align: center;">12.8</td> </tr> </table>																<b>SW300m</b>	<b>S350m</b>	<b>NW500m</b>	<b>NE400m</b>	<b>W300m</b>			8	10	7	8	7			4.3	4.7	4.0	4.2	4.1			12.8	13.5	12.7	12.	12.8
		<b>SW300m</b>	<b>S350m</b>	<b>NW500m</b>	<b>NE400m</b>	<b>W300m</b>																																			
		8	10	7	8	7																																			
		4.3	4.7	4.0	4.2	4.1																																			
		12.8	13.5	12.7	12.	12.8																																			

4.4-17b

		<table border="1" style="width: 100%; border-collapse: collapse;"> <tr> <td></td> <td></td> <td></td> <td></td> <td></td> <td></td> <td></td> </tr> <tr> <td></td> <td></td> <td></td> <td></td> <td></td> <td colspan="3" style="text-align: center;"><b>SW500m</b></td> </tr> <tr> <td></td> <td></td> <td style="text-align: center;"><b>0-0.2m</b></td> <td style="text-align: center;"><b>0.2-0.4m</b></td> <td style="text-align: center;"><b>0.4-0.6m</b></td> <td style="text-align: center;"><b>0-0.2m</b></td> <td style="text-align: center;"><b>0.2-0.4m</b></td> <td style="text-align: center;"><b>0.4-0.6m</b></td> </tr> <tr> <td></td> <td></td> <td style="text-align: center;">6.86</td> <td style="text-align: center;">7.10</td> <td style="text-align: center;">6.</td> <td style="text-align: center;">7.17</td> <td style="text-align: center;">7.23</td> <td style="text-align: center;">6. 7</td> </tr> <tr> <td></td> <td style="text-align: center;">/</td> <td style="text-align: center;">0.46</td> <td style="text-align: center;">0.63</td> <td style="text-align: center;">0.66</td> <td style="text-align: center;">0.45</td> <td style="text-align: center;">0.63</td> <td style="text-align: center;">0.54</td> </tr> <tr> <td></td> <td style="text-align: center;">/</td> <td style="text-align: center;">30.58</td> <td style="text-align: center;">28.24</td> <td style="text-align: center;">2 .02</td> <td style="text-align: center;">21.18</td> <td style="text-align: center;">21.33</td> <td style="text-align: center;">21.02</td> </tr> <tr> <td></td> <td style="text-align: center;">/</td> <td style="text-align: center;">6.32 10<sup>3</sup></td> <td style="text-align: center;">6.40 10<sup>3</sup></td> <td style="text-align: center;">6.32 10<sup>3</sup></td> <td style="text-align: center;">6.80 10<sup>3</sup></td> <td style="text-align: center;">6.70 10<sup>3</sup></td> <td style="text-align: center;">6. 0 10<sup>3</sup></td> </tr> <tr> <td></td> <td style="text-align: center;">/</td> <td style="text-align: center;">2.43 10<sup>3</sup></td> <td style="text-align: center;">2.43 10<sup>3</sup></td> <td style="text-align: center;">2.45 10<sup>3</sup></td> <td style="text-align: center;">2. 7 10<sup>3</sup></td> <td style="text-align: center;">2.70 10<sup>3</sup></td> <td style="text-align: center;">2.74 10<sup>3</sup></td> </tr> <tr> <td></td> <td style="text-align: center;">/</td> <td style="text-align: center;">2.88 10<sup>3</sup></td> <td style="text-align: center;">2.87 10<sup>3</sup></td> <td style="text-align: center;">2.87 10<sup>3</sup></td> <td style="text-align: center;">3.10 10<sup>3</sup></td> <td style="text-align: center;">3.11 10<sup>3</sup></td> <td style="text-align: center;">3.12 10<sup>3</sup></td> </tr> <tr> <td></td> <td style="text-align: center;">/</td> <td style="text-align: center;">834</td> <td style="text-align: center;">830</td> <td style="text-align: center;">833</td> <td style="text-align: center;">865</td> <td style="text-align: center;">862</td> <td style="text-align: center;">873</td> </tr> <tr> <td></td> <td style="text-align: center;">/</td> <td style="text-align: center;">8.2</td> <td style="text-align: center;">8.4</td> <td style="text-align: center;">8.1</td> <td style="text-align: center;">8.5</td> <td style="text-align: center;">8.7</td> <td style="text-align: center;">8.6</td> </tr> <tr> <td></td> <td style="text-align: center;">/</td> <td style="text-align: center;">0.024</td> <td style="text-align: center;">0.031</td> <td style="text-align: center;">0.028</td> <td style="text-align: center;">0.023</td> <td style="text-align: center;">0.025</td> <td style="text-align: center;">0.021</td> </tr> </table>																		<b>SW500m</b>					<b>0-0.2m</b>	<b>0.2-0.4m</b>	<b>0.4-0.6m</b>	<b>0-0.2m</b>	<b>0.2-0.4m</b>	<b>0.4-0.6m</b>			6.86	7.10	6.	7.17	7.23	6. 7		/	0.46	0.63	0.66	0.45	0.63	0.54		/	30.58	28.24	2 .02	21.18	21.33	21.02		/	6.32 10 <sup>3</sup>	6.40 10 <sup>3</sup>	6.32 10 <sup>3</sup>	6.80 10 <sup>3</sup>	6.70 10 <sup>3</sup>	6. 0 10 <sup>3</sup>		/	2.43 10 <sup>3</sup>	2.43 10 <sup>3</sup>	2.45 10 <sup>3</sup>	2. 7 10 <sup>3</sup>	2.70 10 <sup>3</sup>	2.74 10 <sup>3</sup>		/	2.88 10 <sup>3</sup>	2.87 10 <sup>3</sup>	2.87 10 <sup>3</sup>	3.10 10 <sup>3</sup>	3.11 10 <sup>3</sup>	3.12 10 <sup>3</sup>		/	834	830	833	865	862	873		/	8.2	8.4	8.1	8.5	8.7	8.6		/	0.024	0.031	0.028	0.023	0.025	0.021
					<b>SW500m</b>																																																																																																	
		<b>0-0.2m</b>	<b>0.2-0.4m</b>	<b>0.4-0.6m</b>	<b>0-0.2m</b>	<b>0.2-0.4m</b>	<b>0.4-0.6m</b>																																																																																															
		6.86	7.10	6.	7.17	7.23	6. 7																																																																																															
	/	0.46	0.63	0.66	0.45	0.63	0.54																																																																																															
	/	30.58	28.24	2 .02	21.18	21.33	21.02																																																																																															
	/	6.32 10 <sup>3</sup>	6.40 10 <sup>3</sup>	6.32 10 <sup>3</sup>	6.80 10 <sup>3</sup>	6.70 10 <sup>3</sup>	6. 0 10 <sup>3</sup>																																																																																															
	/	2.43 10 <sup>3</sup>	2.43 10 <sup>3</sup>	2.45 10 <sup>3</sup>	2. 7 10 <sup>3</sup>	2.70 10 <sup>3</sup>	2.74 10 <sup>3</sup>																																																																																															
	/	2.88 10 <sup>3</sup>	2.87 10 <sup>3</sup>	2.87 10 <sup>3</sup>	3.10 10 <sup>3</sup>	3.11 10 <sup>3</sup>	3.12 10 <sup>3</sup>																																																																																															
	/	834	830	833	865	862	873																																																																																															
	/	8.2	8.4	8.1	8.5	8.7	8.6																																																																																															
	/	0.024	0.031	0.028	0.023	0.025	0.021																																																																																															



	/						
	/	0.6	0.	0.7	0.6	0.4	0.8
	/	0.12	0.13	0.28	0.23		
	/						
	/						
	/	3.64	5.28	5.1	4.7	5.66	5.43
	/	6.61	7.5	5.01	3.67	8.02	8.25
	/	408	883	140	141	2	40
	/	0.12	0.13	0.28	0.23		
	/						
	/	26.2	30.7	28.3	27.4	32.0	32.8
	/	4.47	4.2	3.75	3.82	5.33	5.41
	/100						
	/						
	/						
	/						
+	/	7.5	10.5	6.35	8.25	8.00	8.35
+	/	1.3 10 <sup>3</sup>	1.43 10 <sup>3</sup>	1.42 10 <sup>3</sup>	1.46 10 <sup>3</sup>	1.48 10 <sup>3</sup>	1.4 10 <sup>3</sup>
2+	/	580	581	580	670	644	64
2+	/	231	236	240	23	262	266
-	/	2.66 10 <sup>3</sup>	2.66 10 <sup>3</sup>	2.65 10 <sup>3</sup>	2.73 10 <sup>3</sup>	2.74 10 <sup>3</sup>	2.75 10 <sup>3</sup>
4 <sup>2-</sup>	/	806	802	800	84	847	850
3 <sup>2-</sup>	/						
3 <sup>-</sup>	/	442	458	464	44	513	51
/ 166-2004						.2	



4.4.3.2

1

1

+ + 2+ 2+ 3<sup>2-</sup> 3<sup>-</sup> - 4<sup>2-</sup>

/ 14848-2017

4.4-16

4.4-18

mg/L pH

1		6.5 8.5	13		0.1
2		3.0	14		1.0
3		450	15		1.0
4		1000	16		0.01
5		0.5	17		0.01
6		20.0	18		0.005
7		1.00	1		250
8		0.002	20		250
		0.001	21		3.0 /100
10		0.05	22		1.0
11		0.05	23		0.05
12		0.3			

3838-2002 1

2

$$S_j = \frac{7.0 - pH_j}{7.0 - pH_{sd}} (pH_j \leq 7.0)$$

$$S_j = \frac{pH_j - 7.0}{pH_{su} - 7.0} (pH_j > 7.0)$$

$S_j$

$j$

$sd$

$su$

$$S_i = \frac{C_i}{C_{0i}}$$



$S_i$      $i$   
 $C_i$      $i$                     /  
 $C_{0i}$      $i$                     /

1

2

4.4-1

4.4-19

		1#	2#	3#	4#	5#
1		1.10	2.28	1.58	2.44	2.38
2		2.06	3. 2	1.06	1.64	5.88
3		2.0	4.44	4.71	3.01	4.18
4		0.71	5.0	4.60	12.31	6. 3
5		1.28	6.06	5.08	4.04	8.40
6		0.84	1. 0	2.68	1.512	2.60
7		5.12	15.56	10.84	8.08	1 . 2
8		0.02	0.05	0.06	0.0	0.05
		0.102	0.003	0.126	0.124	0.015
10						
11						
12						
13		0.0 3	0.128	0.204	0.104	0.0 0
14						
15						
16		0.06	0.02	0.12	0.20	0.12
17		0.141		0.317	0.137	0.108
18		0.0462	4.3	2.78	4.27	6.88
1		0.1	0.80	1.74	0.72	1.05
20		0.001	0.00323	0.00315	0.0038	0.00384
21		0.00208	0.00781	0.0105	0.0126	0.0120
22						
23		0.6	0.7	0.4	0.7	0.6

1# 5#

2.38    5.88    4.71

12.31    8.40    2.60    1 . 2    1#



6.88 3# 5#

1.74

/ 14848-2017

2018

2018 25

26

1

1

2

4.4.3.3

1#

2#

/ 14848-2017

1#

2#



4.4.4

2020 6

1 1 6-5

2 ( )

3 1 1 (8 00-18 00)

(22 00-24 00)

4 30 6-2008

5 4.4-20

4.4-20

dB A

		2020.6.9			
			Leq(A)		Leq(A)
1#	1	11 36	55.0	22 1	47.3
2#	1	11 01	55.4	22 35	47.5
3#	1	11 17	55.1	22 55	47.8
4#	1	11 53	56.1	23 07	48.4



4-5



6

4.4-1

6.4-19

1#	2020.6.	55.0	65	-10.0	47.3	55	-7.7
2#		55.4		- .6	47.5		-7.5
3#		55.1		- .	47.8		-7.2
4#		56.1		-8.	48.4		-6.6

30 6-2008 3



### 4.4.5

#### 4.4.5.1

2020 8 23

2020 721

1

5 2

1

3 4.4-20 4-6

#### 4.4-20

1# 36600

2# 36600

3# 36600

4#



4-6

1:4000



3

4.4- 21

	-1,2-	1,1-	1,2-	1,1-	-1,2-	
		1,1,1-	1,2-	1,1,1,2-	1,1,2,2-	
		1,2-	1,1,2-		1,2,3-	+
	2-		1,4-			
			,	1,2,3-		

4

36600-2018

4.4-22

4.4- 22

	62-2018		--
	/ 17141-1 7		0.01 /
	/ 22105.1-2008		0.002 /
	/ 22105.2-2008		0.01 /
	4 1-201		3 /
	/ 17141-1 7		0.1 /
	4 1-201		1 /
	687-2014	/	2 /
	4 1-201		4 /
	/ 17138-1 7		0.5 /
	1021-201	10- 40	6 /
1,1-	605-2011	/ -	1.0 /
	605-2011	/ -	1.1 /



---

605-2011



	834-2017	-	0.0 /
	834-2017	-	--
2-	834-2017	-	0.04 /
	834-2017	-	0.1 /
	834-2017	-	0.1 /
	834-2017	-	0.2 /
,	834-2017	-	0.1 /
1,2,3-	834-2017	-	0.1 /
	834-2017	-	0.1 /
	834-2017	-	0.1 /
	834-2017	-	0.0 /

5

4.4-23a

mg/kg pH

ng/kg

		S1			S2	S3		
		0-0.5m	0.5-1.5m	1.5-3.0m	0-0.5m	0-0.5m	0.5-1.5m	1.5-3.0m
/	/	0.325	0.323	0.330	0.258	0.270	0.301	0.345
/	/	13.6	20.8	23.1	13.7	8.8	15.1	7.5
/	/	1	15	17	17	18	24	18
/	/	2.04	1.56	1.6	1.84	1.78	2.62	2.57
/	/							
/	/	17.6	26.3	2.2	17.8	18.4	18.8	15.3
/	/	20	30	33	23	22	20	8
/	/		15					
1,1-	/							
	/							
1,2-	/							
/	/	11.7	13.1	12.0	12.6	11.5	10.7	11.1



	/							
1,2-	/							
1,1-	/							
1,2-	/							
	/							
	/							
1,1,1-	/							
	/			28.8				
	/							
	/							
1,2-	/							
	/							
1,1,2-	/							
	/							
1,1,1,2-	/							
	/							
	/							
	/							
	/							
1,1,2,2-	/							
1,2,3-	/							
1,4-	/							
1,2-	/							
	/							
	/							
2-	/							
	/							
	/							
	/							
	/							
,	/							
	/							



1,2,3-								
	/							
	/							
	/							

4.4- 23b

mg/kg

		S4			S5		
		0 0.5m	0.5 1.5m	1.5 3.0m	0 0.5m	0.5 1.5m	1.5 3.0m
		/					
/							
/							
/							
/	7	13	10	10	12	12	
/						1	

4.4- 23c

mg/kg

		S6			S7	S8	S9	S10	S11
		0 0.5m	0.5 1.5m	1.5 3.0m	0-0.5m	0-0.5m	0-0.5m	0-0.5m	0-0.5m
		/							
/									
/									
/									
/	10	8	8	8		7	10	7	
/					6				

4.4-24

		1#		1.17
		118.873443		35.0 5661
		0-0.5	0.5-1.5	1.5-3
		10%	10%	10%



		6.	7.26	7.85
		.05	.12	8. 5
		/	/	/
	/ /	0.72	0.6	0.64
	/ / 3	1100	1200	1600
		43	40	40
1	<< 64-2018 7.3.2 >>			
2				

4.4.5.2

1

$$S_{i,j} = C_{i,j} / C_{si}$$

/

/

2

36600-2018 1 2

4.4-25

4.4-25

mg/kg

		36600-2018
1		60
2		65
3		5.7
4		18000
5		800
6		38
7		00
8		2.8
		0.
10		37
11	1,1-	
12	1,2-	5
13	1,1-	66



14	-1,2-	5 6
15	-1,2-	54
16		616
17	1,2-	5
18	1,1,1,2-	10
1	1,1,2,2-	6.8
20		53
21	1,1,1-	840
22	1,1,2-	2.8
23		2.8
24	1,2,3-	0.5
25		0.43
26		4
27		270
28	1,2-	560
2	1,4-	20
30		28
31		12 0
32		1200
33	+	570
34		640
35		76
36		260
37	2-	2256
38		15
3		1.5
40		15
41		151
42		12 3
43	,	1.5
44	1,2,3-	15
45		70
46		4500

		1#			2#	3#			4#			5#			6#			7#	8#	#	10#	11#
		0 0.5	0.5 1.5	1.5 3	0 0.5	0 0.5	0.5 1.5	1.5 3	0 0.5	0.5 1.5	1.5 3	0 0.5	0.5 1.5	1.5 3	0 0.5	0.5 1.5	1.5 3	0 0.5	0 0.5	0 0.5	0 0.5	0 0.5
1		0.024	0.01	0.02	0.0087	0.0225	0.030	0.0225	/	/	/	/	/	/	/	/	/	/	/	/	/	
2		0.031	0.024	0.026	0.028	0.027	0.040	0.040	/	/	/	/	/	/	/	/	/	/	/	/	/	
3		0.0086	0.0085	0.0087	0.0070	0.0071	0.0080	0.00 0	/	/	/	/	/	/	/	/	/	/	/	/	/	
4		0.227	0.347	0.385	0.228	0.015	0.251	0.125	/	/	/	/	/	/	/	/	/	/	/	/	/	
5		0.0010	0.0015	0.0016	0.0010	0.001	0.001	0.001	/	/	/	/	/	/	/	/	/	/	/	/	/	
6		0.022	0.033	0.037	0.026	0.024	0.022	0.00	0.0078	0.014	0.011	0.011	0.013	0.013	0.011	0.00	0.00	0.00	0.010	0.008	0.011	0.008
7									/	/	/	/	/	/	/	/	/	/	/	/	/	
8			0.0033											0.004	0.002				0.0013			
	1,1-								/	/	/	/	/	/	/	/	/	/	/	/	/	
10									/	/	/	/	/	/	/	/	/	/	/	/	/	
11	1,2-								/	/	/	/	/	/	/	/	/	/	/	/	/	
12		0.027	0.030	0.028	0.02	0.027	0.026	0.027	/	/	/	/	/	/	/	/	/	/	/	/	/	
13									/	/	/	/	/	/	/	/	/	/	/	/	/	
14	1,2-								/	/	/	/	/	/	/	/	/	/	/	/	/	
15	1,1-								/	/	/	/	/	/	/	/	/	/	/	/	/	
16	1,2-								/	/	/	/	/	/	/	/	/	/	/	/	/	
17									/	/	/	/	/	/	/	/	/	/	/	/	/	
18									/	/	/	/	/	/	/	/	/	/	/	/	/	
1	1,1,1-								/	/	/	/	/	/	/	/	/	/	/	/	/	
20									/	/	/	/	/	/	/	/	/	/	/	/	/	
21																						
22									/	/	/	/	/	/	/	/	/	/	/	/	/	
23	1,2-								/	/	/	/	/	/	/	/	/	/	/	/	/	
24									/	/	/	/	/	/	/	/	/	/	/	/	/	
25	1,1,2-								/	/	/	/	/	/	/	/	/	/	/	/	/	
26									/	/	/	/	/	/	/	/	/	/	/	/	/	
27	1,1,1,2-								/	/	/	/	/	/	/	/	/	/	/	/	/	
28									/	/	/	/	/	/	/	/	/	/	/	/	/	
2																						
30																						
31									/	/	/	/	/	/	/	/	/	/	/	/	/	

32	1,1,2,2-								/	/	/	/	/	/	/	/	/	/	/	/	/	/
33	1,2,3-								/	/	/	/	/	/	/	/	/	/	/	/	/	/
34	1,4-								/	/	/	/	/	/	/	/	/	/	/	/	/	/
35	1,2-								/	/	/	/	/	/	/	/	/	/	/	/	/	/
36									/	/	/	/	/	/	/	/	/	/	/	/	/	/
37									/	/	/	/	/	/	/	/	/	/	/	/	/	/
38	2-								/	/	/	/	/	/	/	/	/	/	/	/	/	/
3									/	/	/	/	/	/	/	/	/	/	/	/	/	/
40									/	/	/	/	/	/	/	/	/	/	/	/	/	/
41									/	/	/	/	/	/	/	/	/	/	/	/	/	/
42									/	/	/	/	/	/	/	/	/	/	/	/	/	/
43	1,2,3-								/	/	/	/	/	/	/	/	/	/	/	/	/	/
44									/	/	/	/	/	/	/	/	/	/	/	/	/	/
45									/	/	/	/	/	/	/	/	/	/	/	/	/	/
46									/	/	/	/	/	/	/	/	/	/	/	/	/	/

36600-2018 1 2

---

**5**

**5.1**

**5.1.1**

$$P_i = \frac{\rho_i}{\rho_{0i}} \times 100\%$$

**5.1-1**







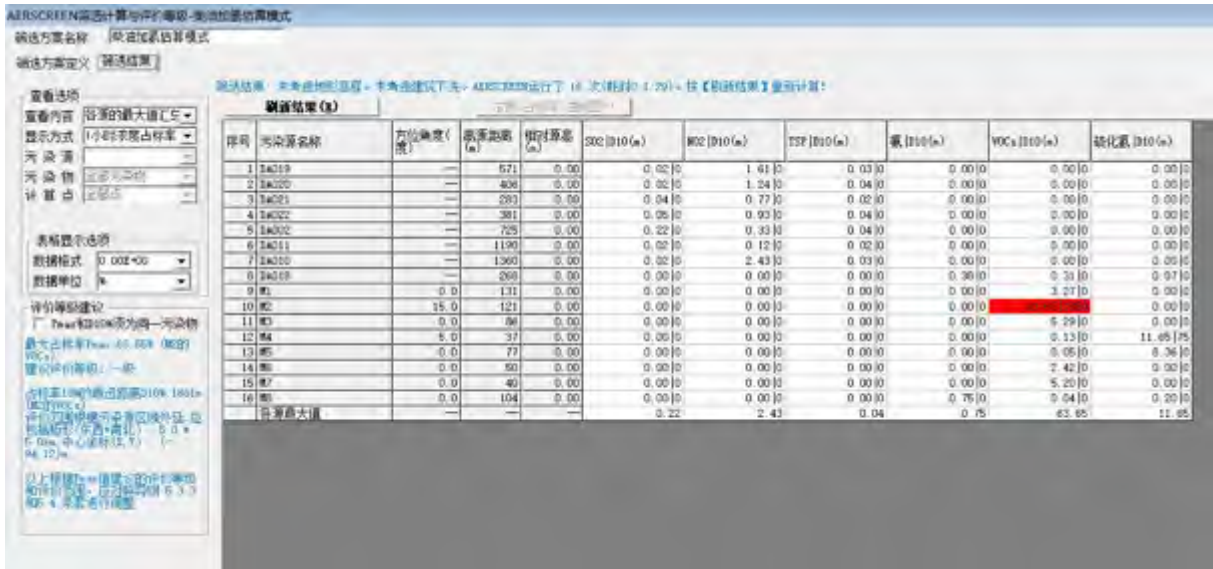

5.1-1a

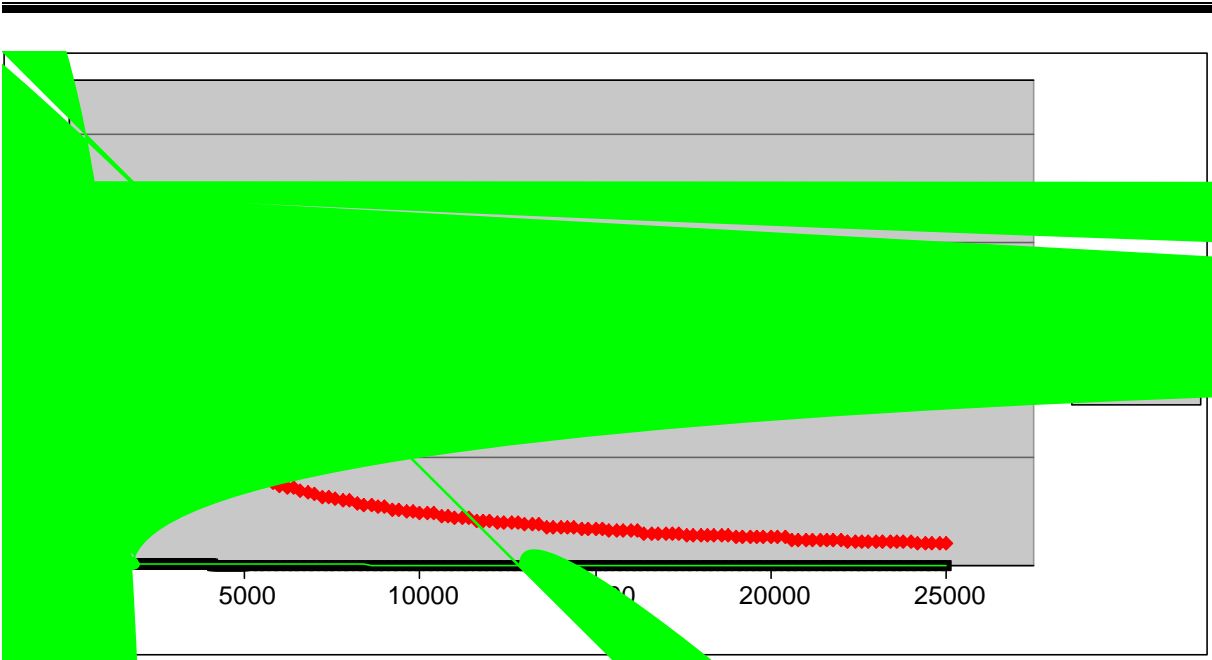

5.1-1b

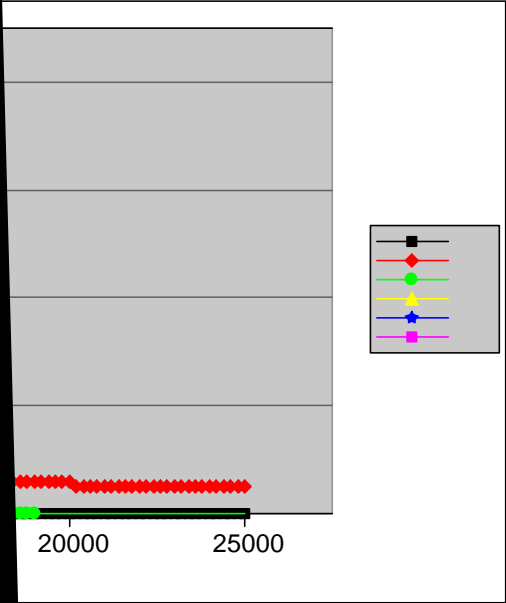

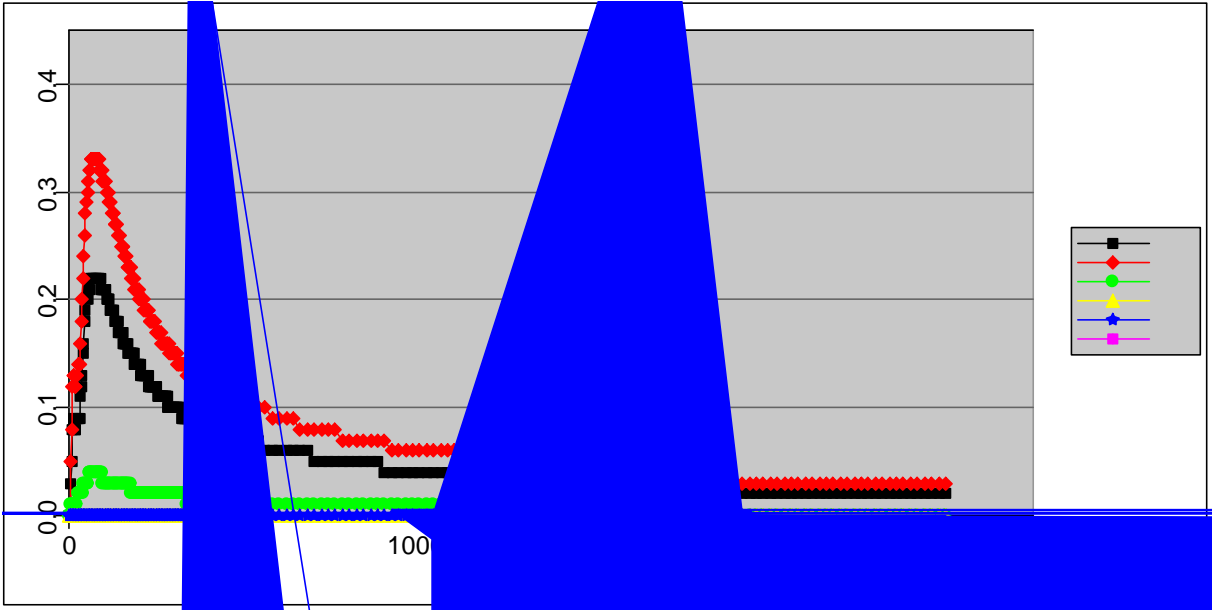



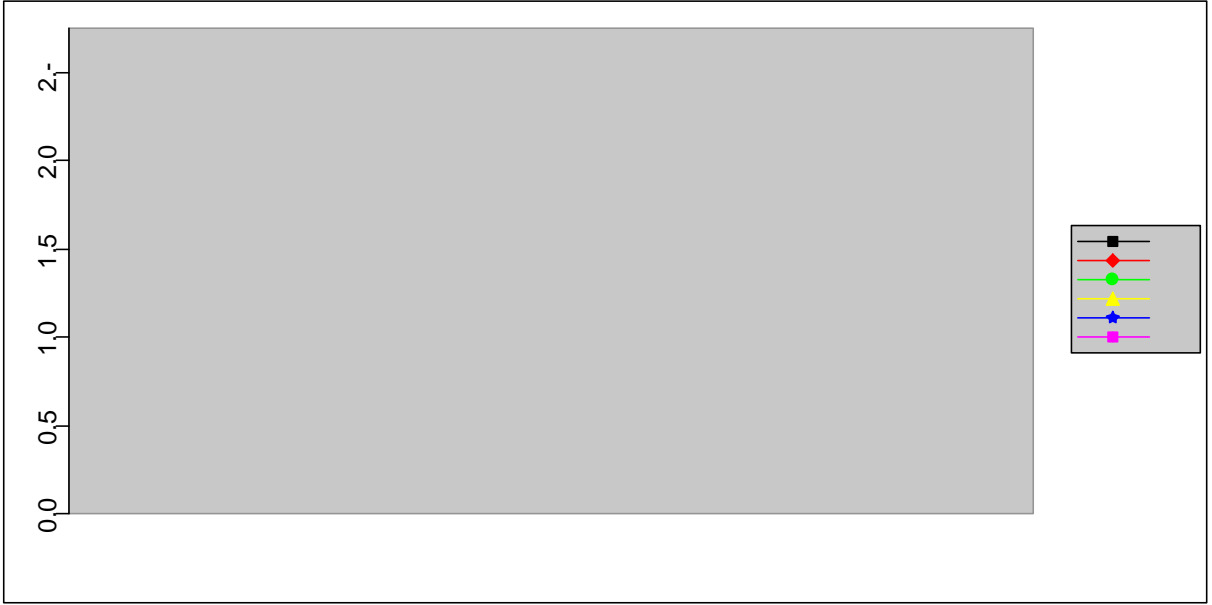

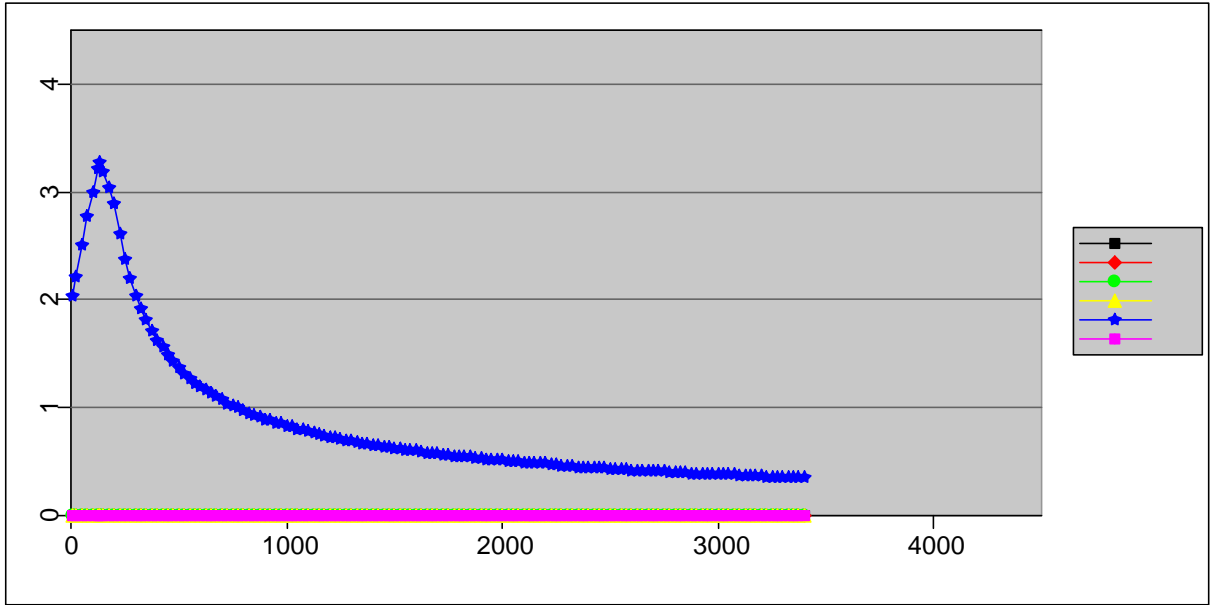

5.1-1j

M1

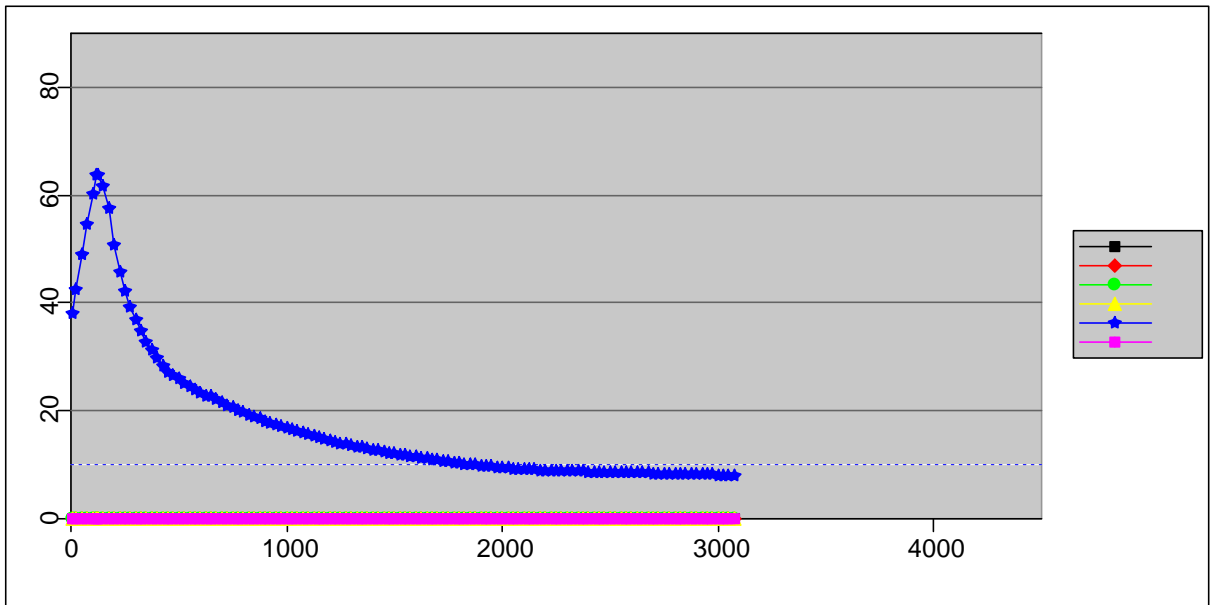

5.1-1k

M2

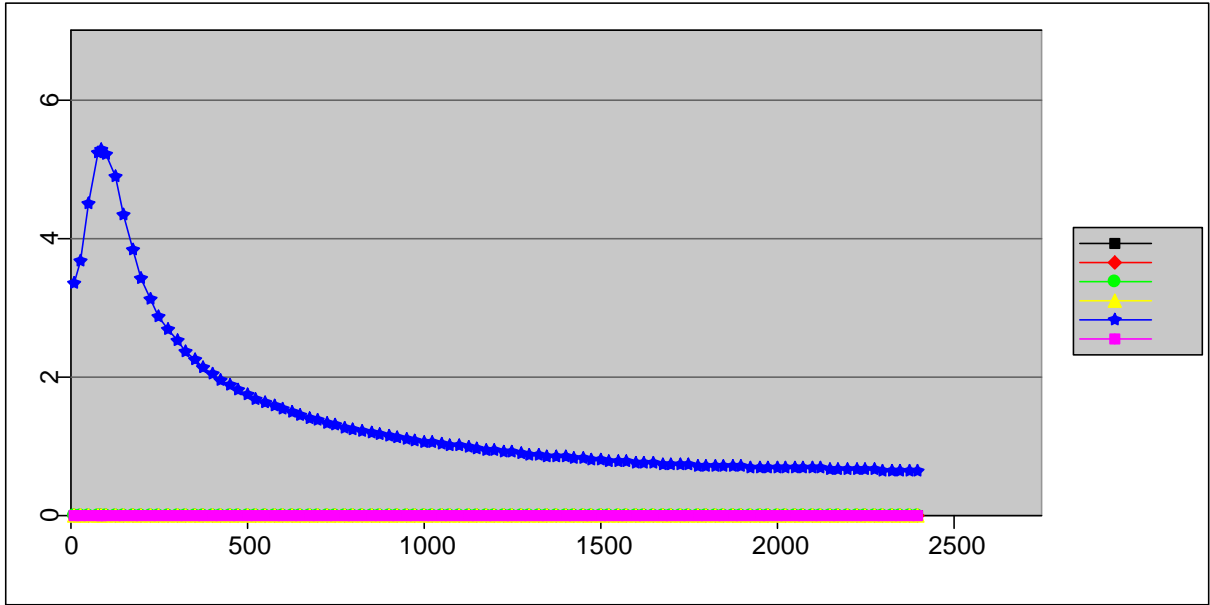

5.1-11

M3

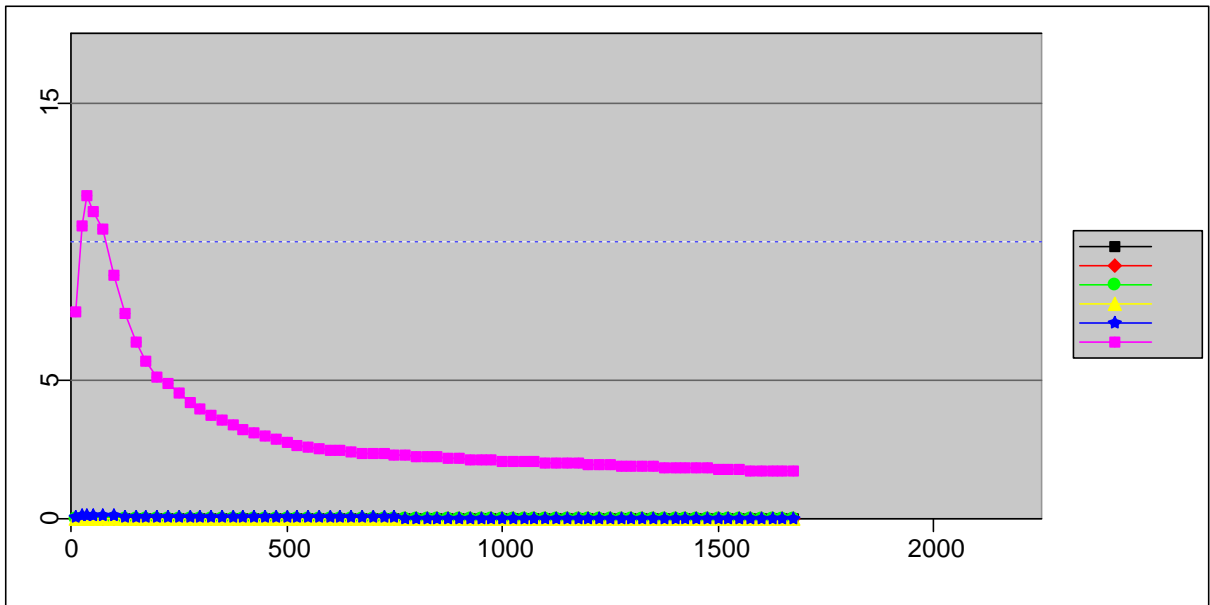

5.1-1m

M4

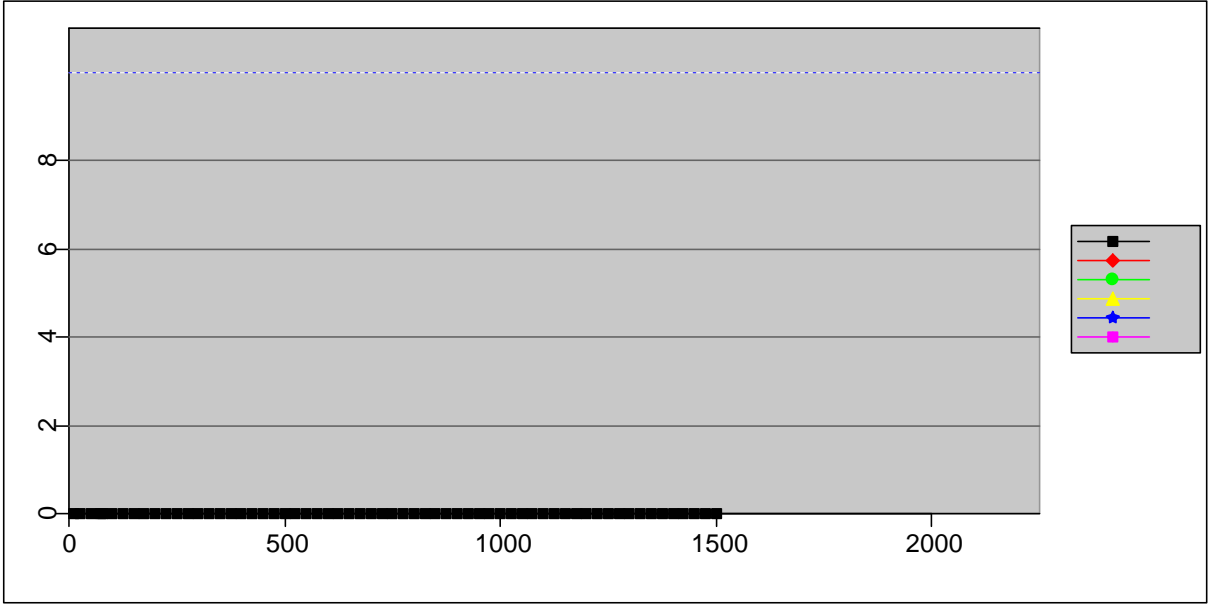

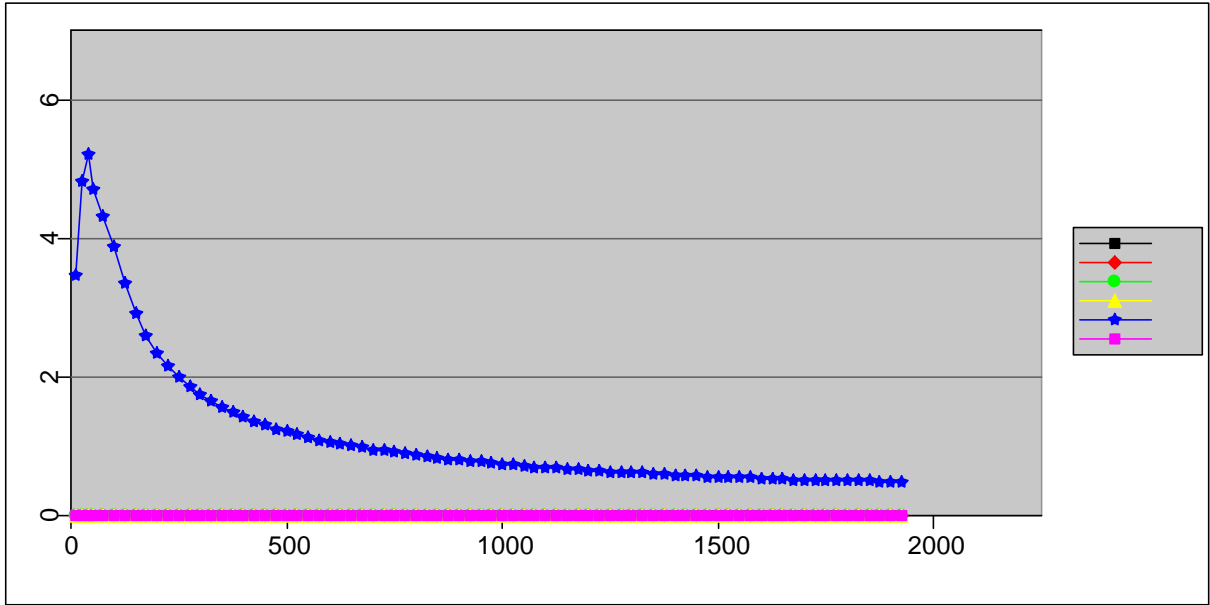

5.1-1p

M7

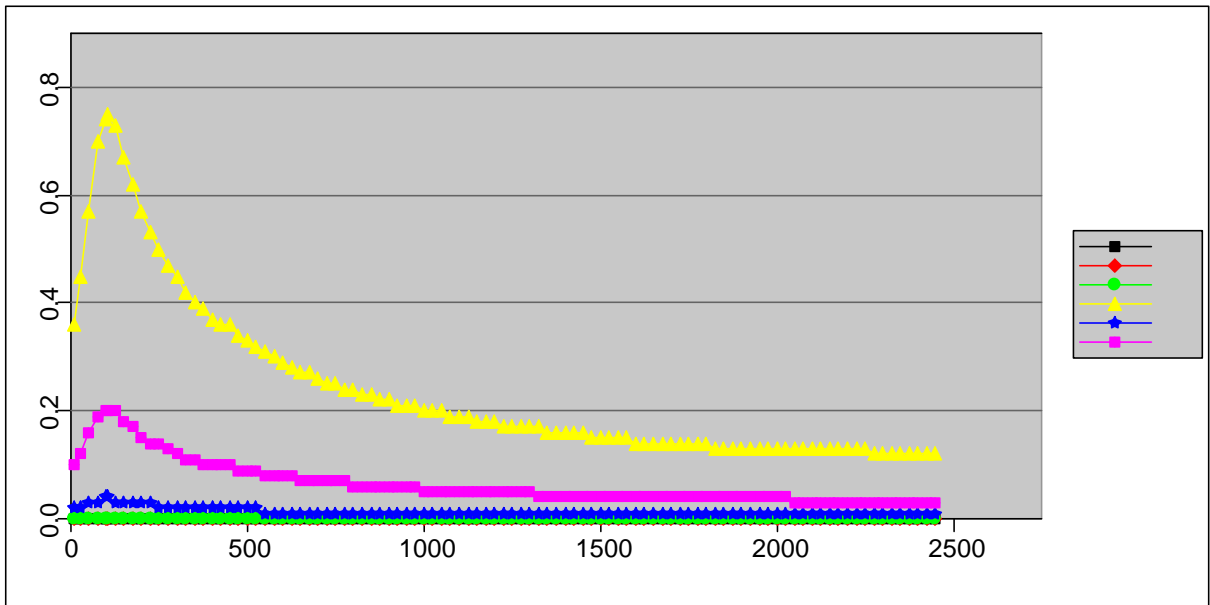

5.1-1q

M8

---

5.1.2

1

5.1-4                      20       1999       2018

5.1-5                      20       1999       2018

---

5.1-2      20      1999      2018





---

**5.1-4a**

**2018**

**5.1-4b**

**2018**



**5.1-9**

**m/s**

**5.1-5**



5.1-10a

2018 /

%



5.1-5a

2018



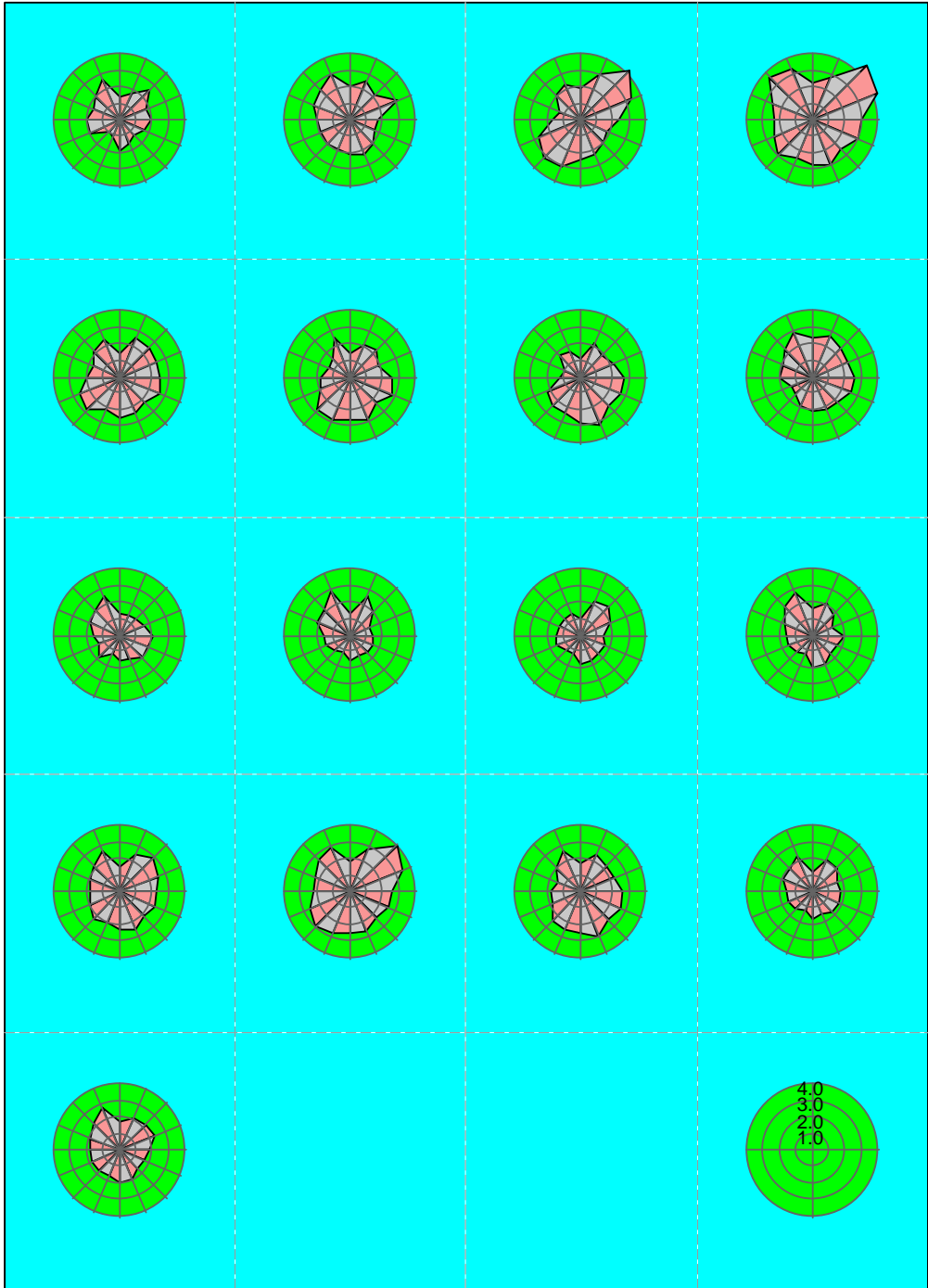

5.1-6

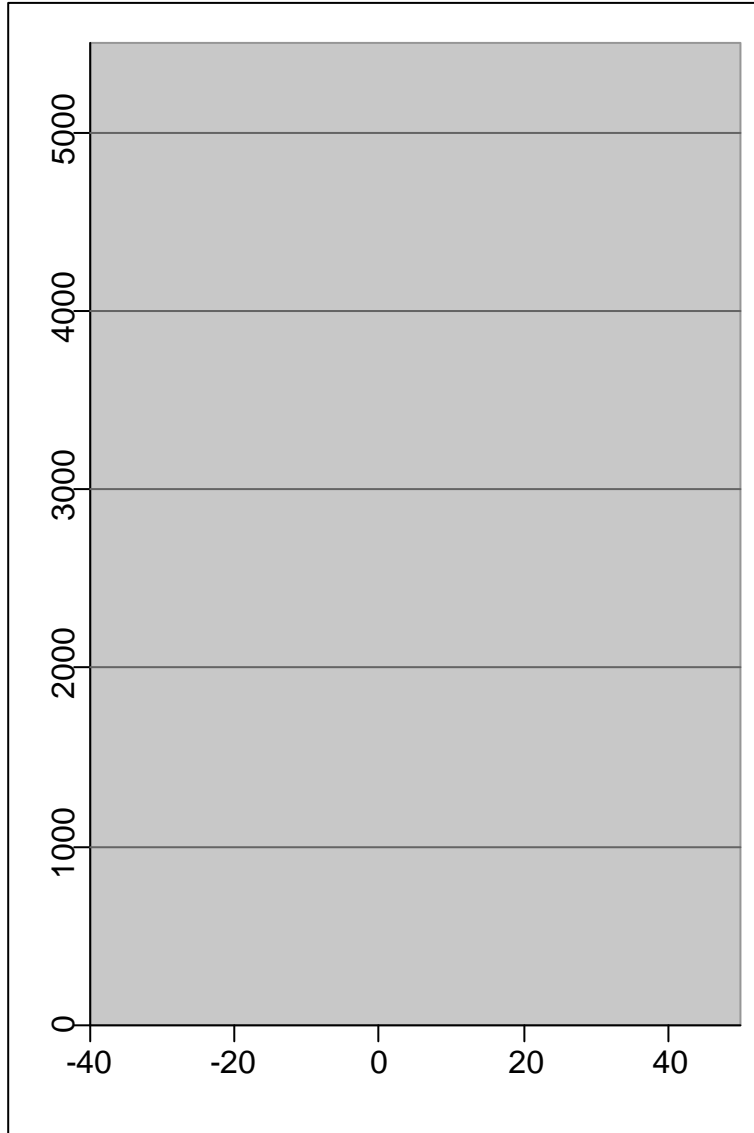

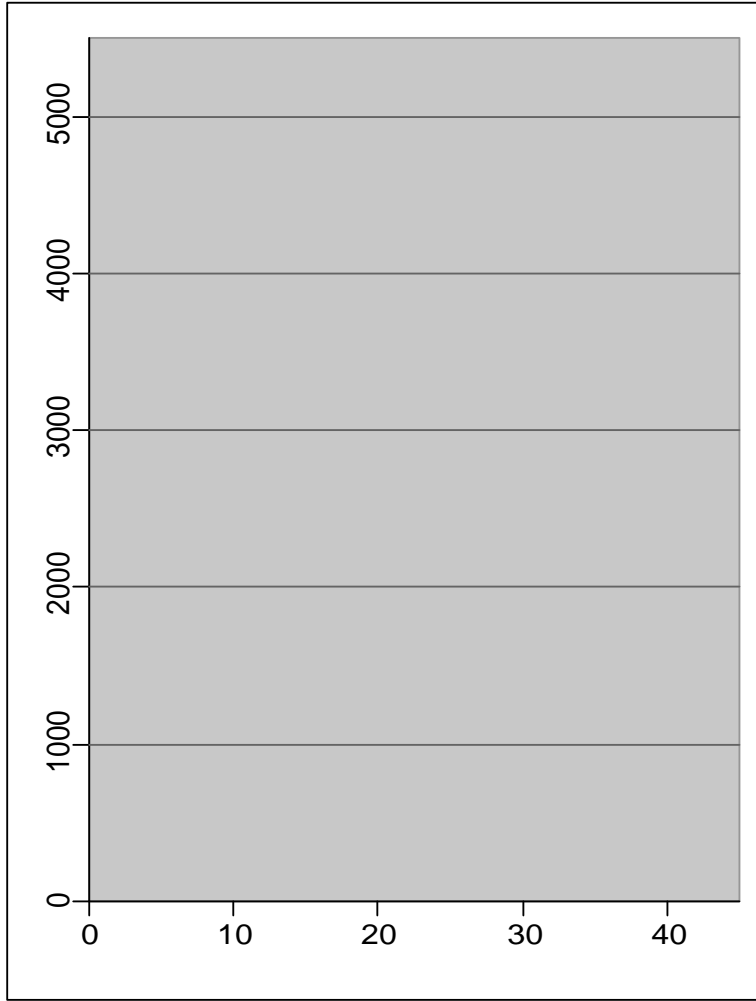

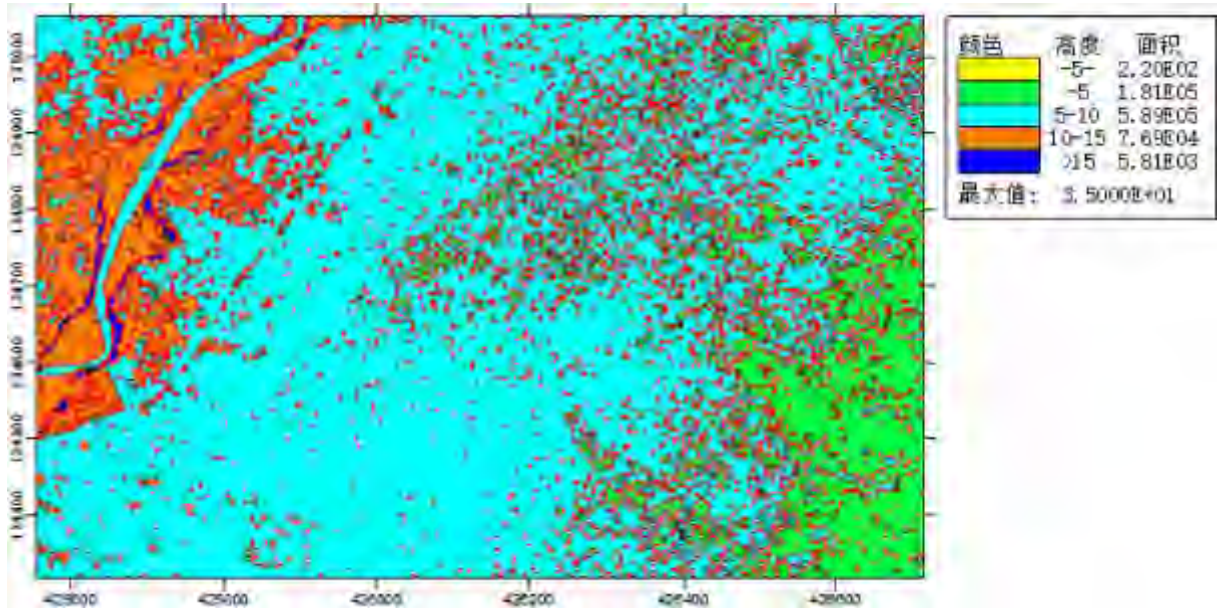

5.1-9









5.1-14

mg/m<sup>3</sup>











**5.1-10**

**1:10000**















5.1-11

SO<sub>2</sub>

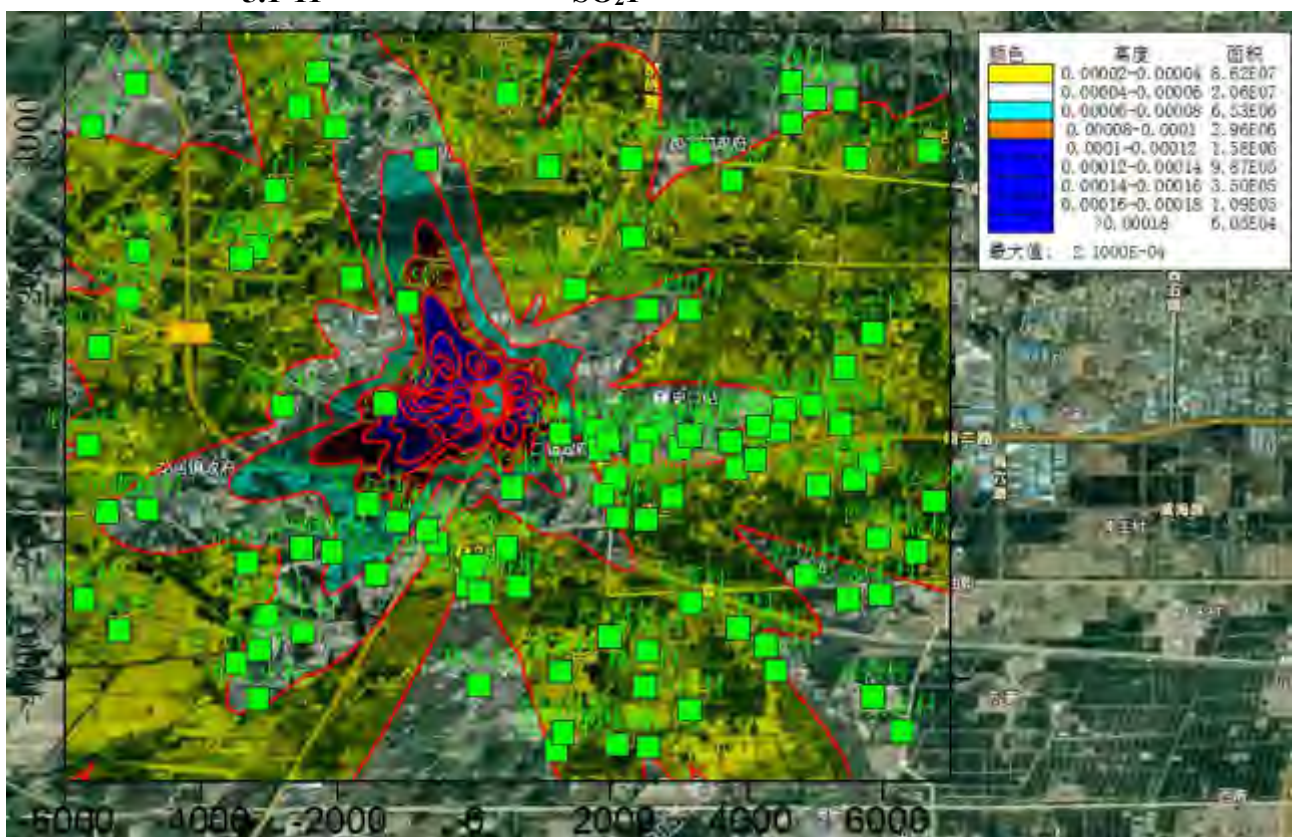

5.1-12

SO<sub>2</sub>



2 NO<sub>x</sub>

5.1-13

SO<sub>2</sub>

5.1-23

NO<sub>x</sub>















5.1-14

NOx1

---

**5.1-15**

**NO<sub>x</sub>**

**5.1-16**

**NO<sub>x</sub>**















---

5.1-17

1

5.1-18





©:na" 3004

Y:EK

DXK: P 2V0 200.

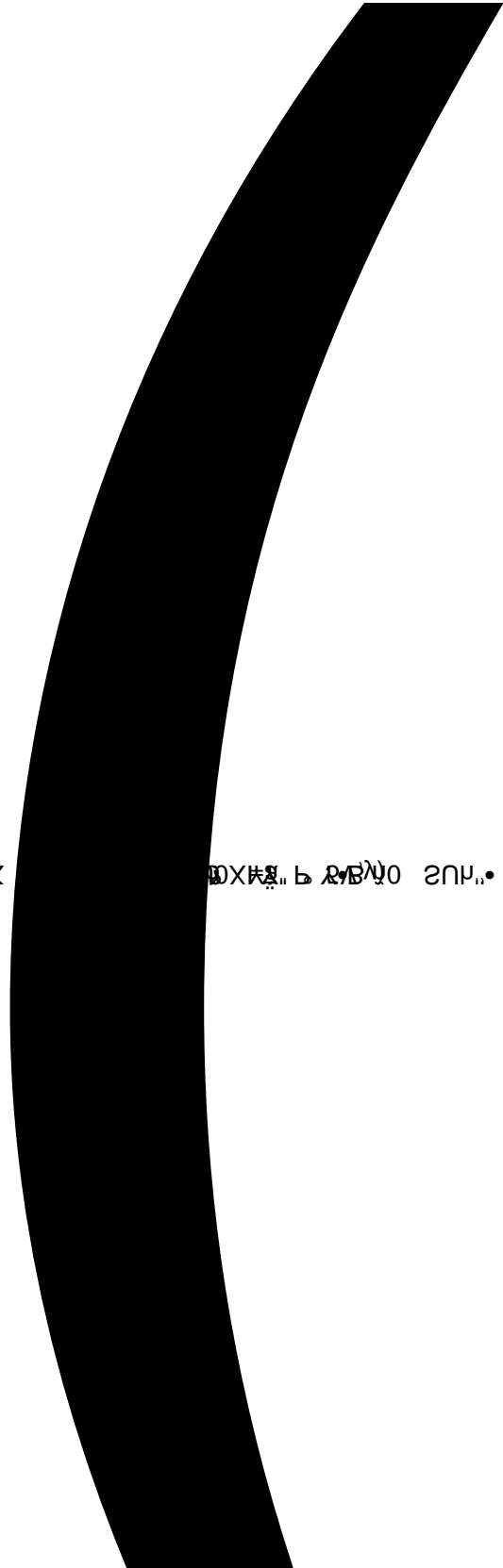















P @













5.1-23 SO<sub>2</sub>





W  
W  
M

(

ØE†

W...W!!









---

5.1-25      **NO<sub>2</sub>**



<b>3</b>	<b>VOCs</b>	<b>5.1-26</b>	<b>NO<sub>2</sub></b>
		<b>5.1-31</b>	<b>VOCs</b>



Q

10 01 02 03 04 05 06 07 08 09 10 11 12 13 14 15 16 17 18 19 20 21 22 23 24 25 26 27 28 29 30 31 32 33 34 35 36 37 38 39 40 41 42 43 44 45 46 47 48 49 50 51 52 53 54 55 56 57 58 59 60 61 62 63 64 65 66 67 68 69 70 71 72 73 74 75 76 77 78 79 80 81 82 83 84 85 86 87 88 89 90 91 92 93 94 95 96 97 98 99 100

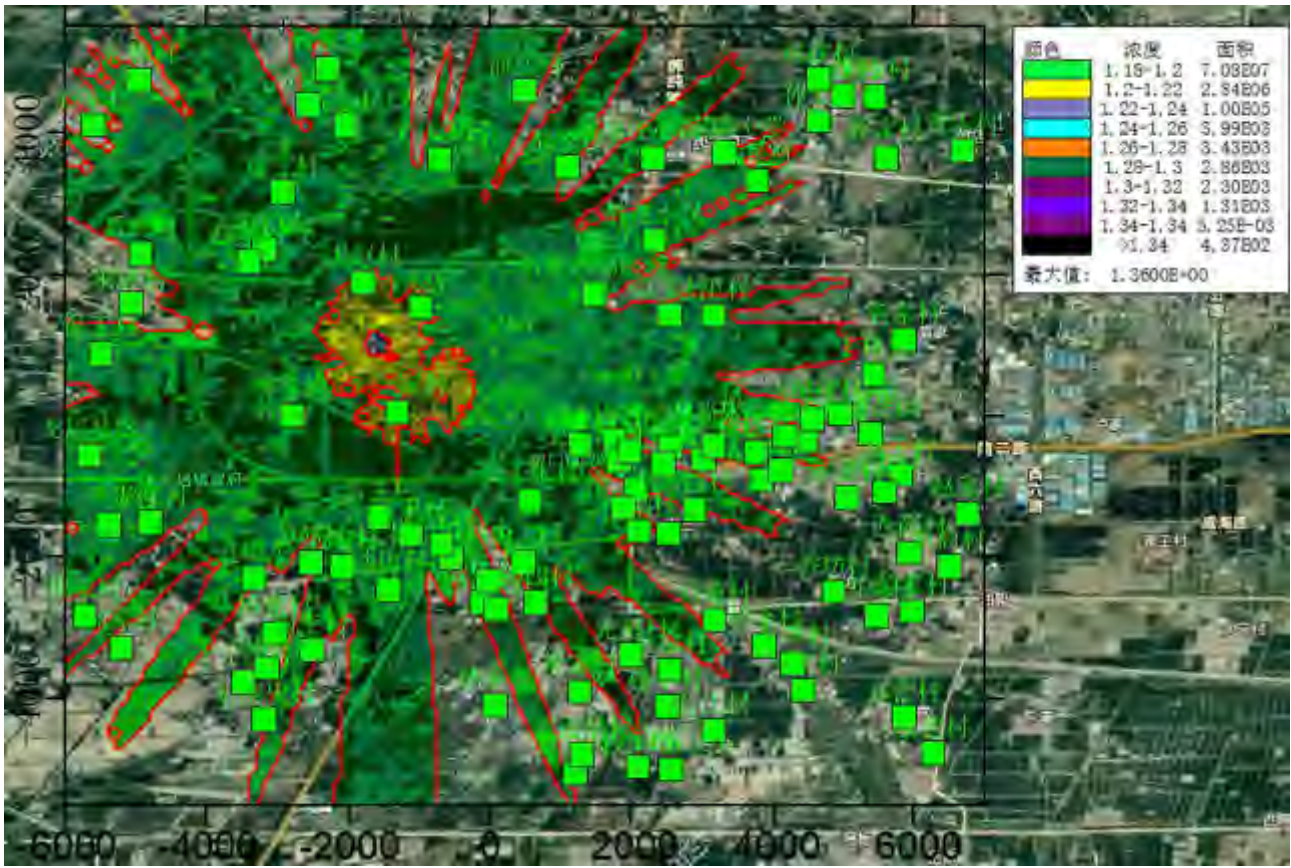

5.1-27 VOCs1

4

5.1-32











5.1-34

mg/m<sup>3</sup>

Handwritten text at the bottom of the page, appearing to be a signature or name, possibly "Handwritten".

10

$$k = [\bar{c}_{\text{本项目}(a)} - \bar{c}_{\text{区域削减}(a)}] / \bar{c}_{\text{区域削减}(a)} \times 100\%$$

$\bar{c}_{\text{本项目}(a)}$

$\bar{c}_{\text{区域削减}(a)}$

5.1-35

11

5.1-36

SO<sub>2</sub>1

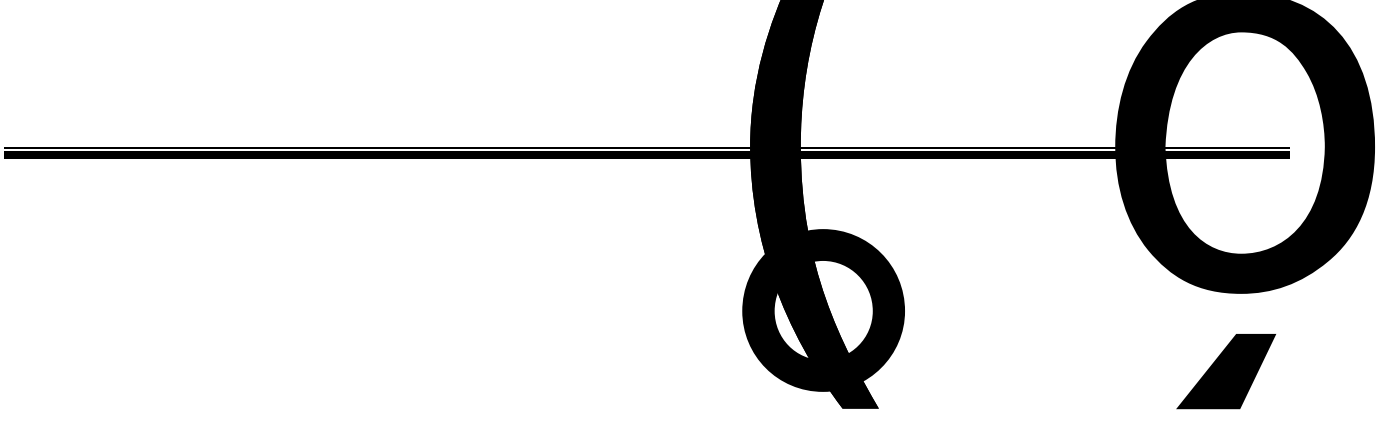

& £ w

w





**5.1-33**

**SO<sub>2</sub>1**

---

**5.1.3**

**5.1-37**

**5.1.4**

5.1-38





---

---

**5.1-40**

**5.1.7**

5.1-41

					<input checked="" type="checkbox"/>		
					<input checked="" type="checkbox"/>		
					<input checked="" type="checkbox"/>		
							<input type="checkbox"/>
						<input checked="" type="checkbox"/>	<input type="checkbox"/>
						<input checked="" type="checkbox"/>	<input type="checkbox"/>

---

**5.2**

**5.2.1**

**5.2.1.1**

**5.2-1**

		<b>Q/ m<sup>3</sup>/d</b> <b>W/</b>
<b>B</b>		

**5.2.1.2**

---

**5.2.1.3**

**5.2.2**

**5.2.2.1**









5.2.2.2

2-

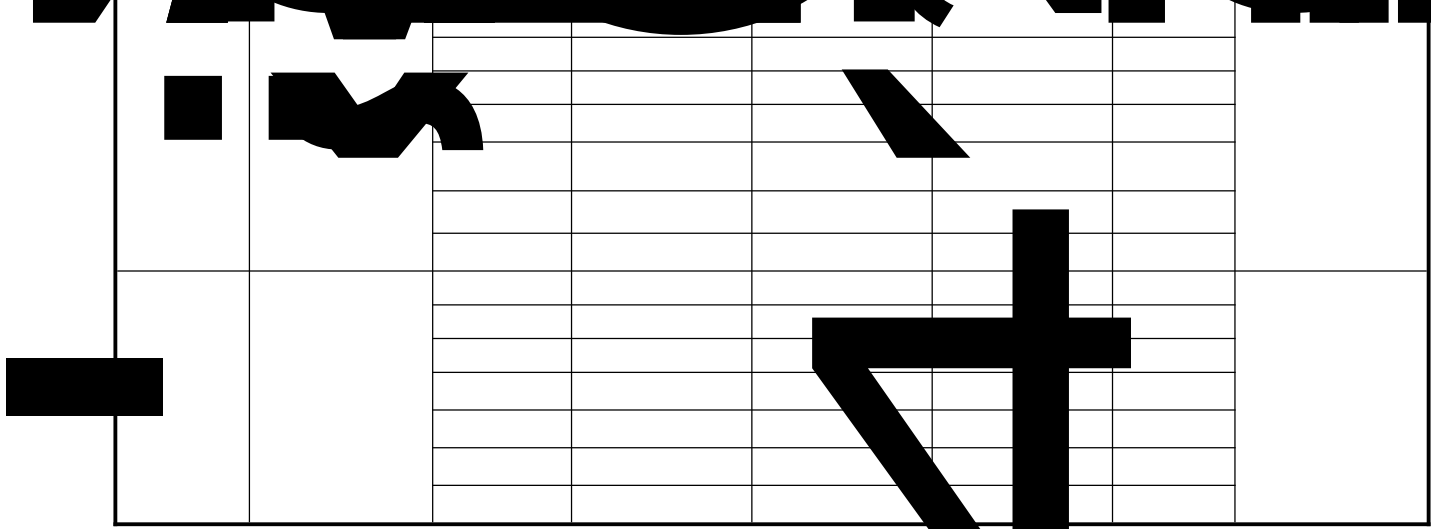

5.2.2.3

---

5.2.2.4

1

5.2-3

			/ mg/L	/ t/d	/ t/a

---

2

3

4

5

1

$$L_m = 0.11 + 0.7 \left[ 0.5 - \frac{a}{B} - 0.11 \left( 0.5 - \frac{a}{B} \right)^2 \right]^{\frac{1}{2}} \frac{uB^2}{E_y}$$

$$E_y = 0.15hu^*$$

$$u^* = \sqrt{gh}$$

---

---

5.2-4

2

$$\alpha = \frac{kE_x}{u^2}$$
$$P_E = \frac{uB}{E_x}$$
$$E_x = 5.93hu^*$$

**5.2-5      $\alpha$    Pe**

<b>9</b>	<b><math>\alpha</math></b>		<b><math>7.18 \times 10^{-7}</math></b>	<b><math>3.59 \times 10^{-7}</math></b>	<b>0</b>	<b><math>6.81 \times 10^{-7}</math></b>	<b><math>3.40 \times 10^{-7}</math></b>	<b>0</b>	<b><math>4.73 \times 10^{-7}</math></b>	<b><math>2.36 \times 10^{-7}</math></b>	<b>0</b>
<b>10</b>	<b>Pe</b>		<b>11.13</b>	<b>11.13</b>	<b>11.13</b>	<b>10.56</b>	<b>10.56</b>	<b>10.56</b>	<b>12.26</b>	<b>12.26</b>	<b>12.26</b>

---

$$C = C_0 \exp\left(-\frac{kx}{u}\right) \quad x \geq 0$$

$$C_0 = (C_p Q_p + C_h Q_h) / (Q_p + Q_h)$$

5.2-6

---

5.2-7

---

5.2.2.5

5.2.2.6

5.2.2.7

1



---

5.2.3

1

2

5.2-10



#1 ‰



! „9E3» ь H 2 22” 0A9„ . 0CD ь „G4t 2 0

B 3 5 0 a

		<input checked="" type="checkbox"/> <input type="checkbox"/> <input checked="" type="checkbox"/>				
		<input checked="" type="checkbox"/>				
		<input checked="" type="checkbox"/>				
					<input checked="" type="checkbox"/>	<input checked="" type="checkbox"/> <input checked="" type="checkbox"/>
<input checked="" type="checkbox"/>						
		<input checked="" type="checkbox"/>				
		<input checked="" type="checkbox"/>				

---

## 5.3

### 5.3.1

1

2

---

3

5.3-1



IONEL B

4

S

X



---

5.3-3

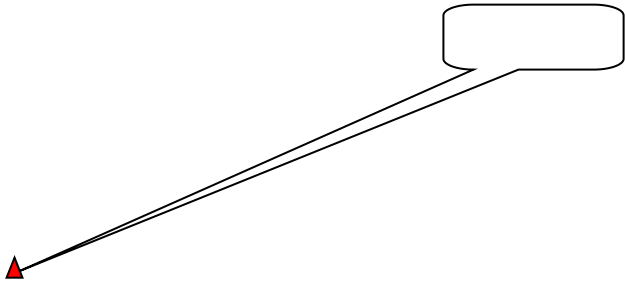

5.3-3

1:1000000

5

5.3-4

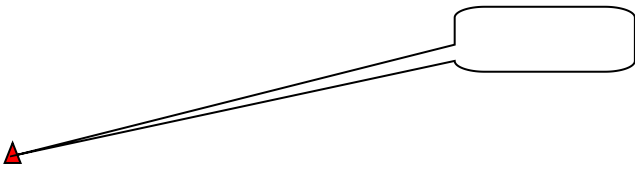

5.3-4







5.3-5



5.3-7

---

5.3-7

272



6

8

9







## 钻孔柱状图

工程名称				东营海热热力供应有限公司集中供热站项目				工程编号		2016050			
孔号		109		坐标		X=4142475.409m Y=659089.013m		钻孔直径		110mm			
孔口标高		3.80m		稳定水位		1.00m		初见水位		2016.10.22			
地质时代	层号	层底标高 (m)	层底深度 (m)	分层厚度 (m)	柱状图	岩性描述				标高	层数	附注	
					1:200								
Q <sub>4</sub> <sup>al</sup>	1	2.46	1.40	1.06	▲	素填土: 黄褐色-灰褐色, 土质不均匀, 以粉土为主, 夹黏性土团块, 含植物根茎。							
Q <sub>4</sub> <sup>al</sup>	2	2.09	1.80	0.29	●	粉土: 黄褐色, 中密, 湿, 摇震反应迅速, 无光泽反应, 低干强度, 低塑性, 土质不均匀, 夹粉质黏土薄层。							
Q <sub>4</sub> <sup>al</sup>	2	1.66	2.20	0.54	●	粉质黏土: 黄褐色, 软塑, 稍有光泽, 中等干强度, 中等塑性, 土质不均匀, 夹粉土薄层。							
Q <sub>4</sub> <sup>al</sup>	3	-1.04	3.80	2.19	●	粉土: 黄褐色, 中密, 湿, 摇震反应迅速, 无光泽反应, 低干强度, 低塑性, 土质不均匀, 夹粉质黏土薄层。							
Q <sub>4</sub> <sup>al</sup>	3	-4.14	5.00	1.80	●	粉质黏土: 黄褐色-灰褐色, 软塑, 稍有光泽, 中等干强度, 中等塑性, 土质不均匀, 夹粉土薄层。							
Q <sub>4</sub> <sup>al</sup>	4	-6.74	10.20	3.20	●	粉土: 灰褐色, 中密, 湿, 摇震反应迅速, 无光泽反应, 低干强度, 低塑性, 土质较均匀。							
Q <sub>4</sub> <sup>al</sup>	5	-7.84	11.70	1.50	●	粉质黏土: 黄褐色-灰褐色, 软塑, 稍有光泽, 中等干强度, 中等塑性, 土质不均匀, 夹粉土薄层。							
Q <sub>4</sub> <sup>al</sup>	6	-9.64	13.20	1.50	●	粉土: 灰褐色, 中密, 湿, 摇震反应迅速, 无光泽反应, 低干强度, 低塑性, 土质不均匀, 含贝壳碎屑, 砂粒含量较高, 局部达粉砂。							
Q <sub>4</sub> <sup>al</sup>	6	-10.74	14.00	1.10	●	粉质黏土: 灰褐色, 软塑, 稍有光泽, 中等干强度, 中等塑性, 土质不均匀, 夹粉土薄层。							
Q <sub>4</sub> <sup>al</sup>	6	-12.14	16.00	1.80	●	粉土: 灰褐色, 中密, 湿, 摇震反应迅速, 无光泽反应, 低干强度, 低塑性, 土质不均匀, 夹粉质黏土薄层, 含少量贝壳碎屑。							
Q <sub>4</sub> <sup>al</sup>	6	-13.64	17.80	1.90	●	粉质黏土: 灰褐色, 软塑, 稍有光泽, 中等干强度, 中等塑性, 土质不均匀, 夹粉土薄层。							
Q <sub>4</sub> <sup>al</sup>	7	-17.34	21.20	3.20	●	粉土: 灰褐色, 中密, 湿, 摇震反应迅速, 无光泽反应, 低干强度, 低塑性, 土质不均匀, 夹粉质黏土薄层, 含少量贝壳碎屑。							
Q <sub>4</sub> <sup>al</sup>	8	-18.64	22.80	1.30	●	粉质黏土: 灰褐色, 软塑, 稍有光泽, 中等干强度, 中等塑性, 土质较均匀, 局部夹粉土薄层。							
Q <sub>4</sub> <sup>al</sup>	9	-22.44	26.30	3.80	●	粉土: 灰褐色, 中密, 湿, 摇震反应迅速, 无光泽反应, 低干强度, 低塑性, 土质较均匀。							
Q <sub>4</sub> <sup>al</sup>	9	-24.04	27.90	1.60	●	粉质黏土: 灰褐色-黄褐色, 可塑, 稍有光泽, 中等干强度, 中等塑性, 土质不均匀, 夹粉土薄层, 偶见菱石。							
Q <sub>4</sub> <sup>al</sup>	9	-25.94	29.80	1.90	●	粉土: 灰褐色, 中密, 湿, 摇震反应迅速, 无光泽反应, 低干强度, 低塑性, 土质不均匀, 夹粉质黏土薄层。							
Q <sub>4</sub> <sup>al</sup>	9	-27.44	31.70	1.90	●	粉质黏土: 灰褐色-黄褐色, 可塑, 稍有光泽, 中等干强度, 中等塑性, 土质不均匀, 夹粉土薄层, 偶见菱石。							
Q <sub>4</sub> <sup>al</sup>	9	-29.34	33.60	1.90	●	粉土: 灰黄色-黄褐色, 中密, 湿, 摇震反应迅速, 无光泽反应, 低干强度, 低塑性, 土质不均匀, 砂粒含量较高, 局部达粉砂, 上部夹粉质黏土薄层。							
Q <sub>4</sub> <sup>al</sup>	10	-32.64	36.90	6.70	●	黏土: 红褐色-黄褐色, 可塑, 稍有光泽, 中等干强度, 中等塑性, 土质较均匀, 局部夹粉土薄层, 偶见菱石。							
Q <sub>4</sub> <sup>al</sup>	11	-37.94	41.80	5.20	●	粉土: 黄褐色-灰褐色, 中密, 湿, 摇震反应迅速, 无光泽反应, 低干强度, 低塑性, 土质不均匀, 黏粒含量较高, 夹粉质黏土薄层。							
Q <sub>4</sub> <sup>al</sup>	12	-38.64	42.00	0.70	●	粉质黏土: 灰褐色, 可塑, 稍有光泽, 中等干强度, 中等塑性, 土质不均匀, 夹粉土薄层。							
Q <sub>4</sub> <sup>al</sup>	12	-41.64	45.40	2.90	●	粉土: 黄褐色-灰褐色, 中密, 湿, 摇震反应迅速, 无光泽反应, 低干强度, 低塑性, 土质不均匀, 黏粒含量较高, 夹粉质黏土薄层。							
Q <sub>4</sub> <sup>al</sup>	12	-43.44	47.30	1.90	●	粉质黏土: 黄褐色, 可塑, 稍有光泽, 中等干强度, 中等塑性, 土质较均匀, 局部夹粉土薄层。							
Q <sub>4</sub> <sup>al</sup>	13	-48.04	51.90	4.60	●	粉土: 黄褐色, 中密, 湿, 摇震反应迅速, 无光泽反应, 低干强度, 低塑性, 土质较均匀, 局部夹粉土薄层, 含贝壳碎屑。							
Q <sub>4</sub> <sup>al</sup>	14	-51.84	55.20	3.80	●	粉质黏土: 黄褐色, 可塑, 稍有光泽, 中等干强度, 中等塑性, 土质不均匀, 夹粉土薄层, 含贝壳碎屑。							
Q <sub>4</sub> <sup>al</sup>	15	-58.14	62.00	6.30	●	粉土: 黄褐色, 中密, 湿, 摇震反应迅速, 无光泽反应, 低干强度, 低塑性, 土质不均匀, 夹粉质黏土薄层。							
Q <sub>4</sub> <sup>al</sup>	16	-64.44	68.30	6.20	●	粉质黏土: 灰褐色, 可塑, 稍有光泽, 中等干强度, 中等塑性, 土质较均匀, 局部夹粉土薄层。							
Q <sub>4</sub> <sup>al</sup>	17	-66.14	70.00	1.70	●	粉质黏土: 灰褐色, 可塑, 稍有光泽, 中等干强度, 中等塑性, 土质较均匀, 局部夹粉土薄层。							

东营市中汇工程勘察设计有限公司  
 外业日期: 2016.10.21





5.3-3

5.3-4

---

**5.3.2**

**5.3.2.1**

**1**

**L**

**5.3-4a**

<b>L</b>				

**2**

**5.3-5**



---

5.3.2.4

5.3.3

5.3.3.1

1

2



3

5.3.3.2



---

2

3

5.3-8

mg/L

4

---

---

5.3-8a

5

$$\left( \quad \right) = \frac{\quad}{\pi \sqrt{\quad}} \quad \left[ \begin{array}{c} (-) \\ + \end{array} \right]$$

6



---

---

**5.3-9 COD 10**

**2 100d COD**

**5.3-11**

**100dCOD**



---

**5.3-11 COD 1000**

**4 5000d COD**

**5.3-13 5000dCOD**

---

---

**5.3-12 COD 5000**

**10d**

**5.3-14 10dCOD<sub>Mn</sub>**

---

---

**5.3-13**

**10d**

**100d**





---

---

**5.3-15          1000d**

**5000d**





---

**5.3.4.3**

**5.3.5**

**5.3.5.1**

**5.3.5.2**



**5.3-18**

**5.3-19**

**5.3-20**

---

---



---

5.3.5.3

---

5.3-21





---

## 5.3.6

L

## 5.4

### 5.4.1

#### 5.4.1.1

#### 5.4.1.2

### 5.4.2

#### 5.4.2.1

5.4-1

5.4.2.2

5.4.2.3

5.4.2.4

$$L_A(r) = L_{Aw} - D_c - A \quad (1)$$

或  $L_A(r) = L_A(r_0) - A \quad (2)$

$$A = A_{div} + A_{atm} + A_{gr} + A_{bar} + A_{misc} \quad (3)$$

---

$$L_{p2} = L_{p1} - (TL + 6) \quad (4)$$

$$L_w = L_{p2}(T) + 10 \lg s$$



---

## **5.4.3**

### **5.4.3.1**

### **5.4.3.2**

---

2

#### 5.4.4

1

2

#### 5.5

##### 5.5.1

##### 5.5.1.1



5.5-1

5.5-2

/



---

---

**5.5-3**

**5.5-4**

	I			II			III		

**5.5.1.3**

---

2

3

5.5.1.4

1

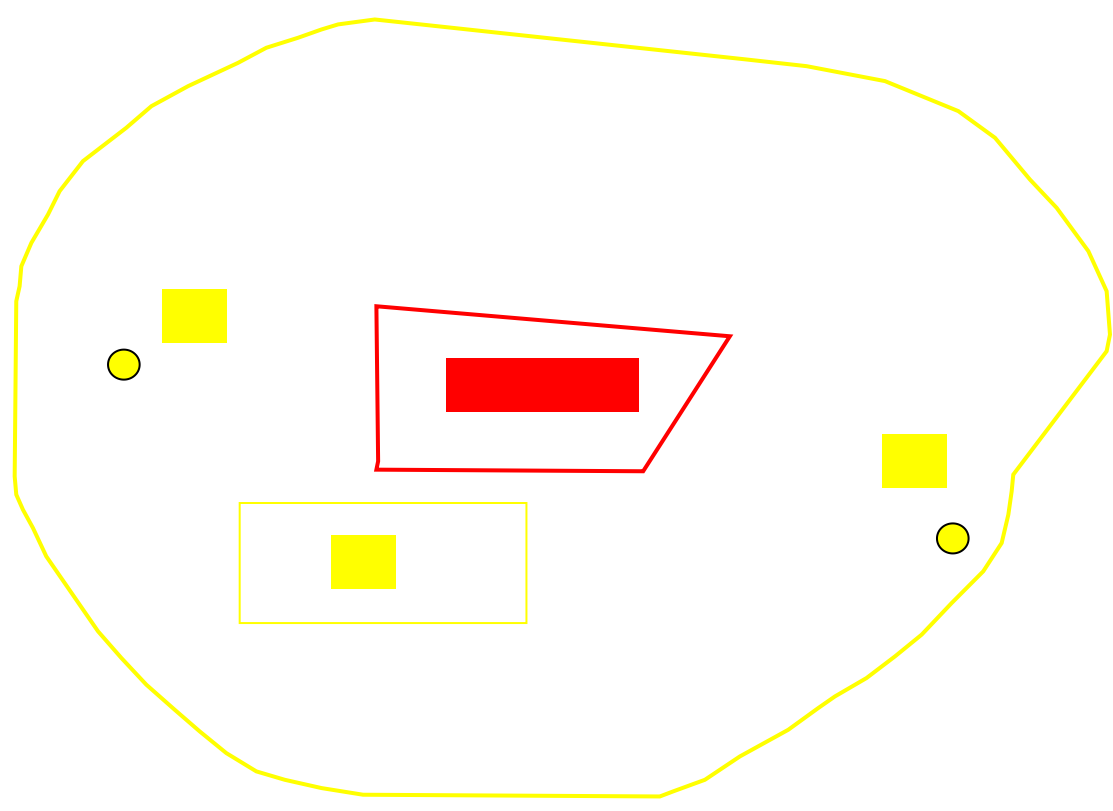

5.5-1

1:25000

2

3

4

$$\left\{ \begin{array}{lll} \frac{\partial(\theta c)}{\partial t} = \frac{\partial}{\partial z} \left( \theta D \frac{\partial c}{\partial z} \right) - \frac{\partial}{\partial z} (qc) & & \\ c(z, t) = 0 & t = 0 & L \leq z < 0 \\ c(z, t) = c_0 & t > 0 & z = 0 \\ -\theta D \frac{\partial c}{\partial z} = 0 & t > 0 & z = L \end{array} \right.$$

---

$$-\theta D \frac{\partial c}{\partial z} = 0 \quad t > 0, z = L$$

6

---

---

5.5-5

5.5-6

5.5-7



5.5-2

-

5.5-3

-



**5.5.1.5**



5.5-8

5.5.1.7

5.5-9

			<input checked="" type="checkbox"/>		<input type="checkbox"/>
		<input checked="" type="checkbox"/>	<input type="checkbox"/>		
			<input checked="" type="checkbox"/>		

---

## 5.5.2

### 5.5.2.1

1 50 /

2 30 /

---

3

4

5





---

5.5-8

t/a

t/a



---

### 5.5.2.2

1

2

### 5.5.2.3

### 5.5.2.4



5.5.2.5

---

**5.6**

**5.6.1**

**1**





---

---



6.6-3

3

1

1



2

3



4

2

3

---

4

1

**MTBE**

---

2

3



4

1

2

3

---

4

5

6

7

5

---

**5.6.2**

**5.6.2**

**1**



---

---

5.6-2

5.6-3

P

(Q)	M			
	M1	M2	M3	M4

---

---

**5.6-4**

**5.6-5**

**5.6-7**

---



---

**5.6-7**

	<b>F1</b>	<b>F2</b>	<b>F3</b>

---

---

**5.6-8**

**5.6-9**

**5.6-10**

	<b>G1</b>	<b>G2</b>	<b>G3</b>

**5.6-11**

E	P			
	P1	P2	P3	P4

4

**5.6-12**

**5.6.4**

**5.6.4.1**

**5.6-13a**

---

---

5.6-13

---

---

5.6-14





---



---



**5.6-19**

**5.6.4.2**

**5.6-20**

---

### 5.6.4.3

1

2

---



**5.6.4.4**

**5.6-21**







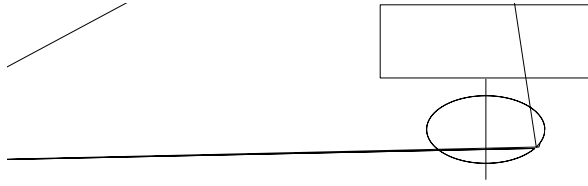

**5.6.5.3**

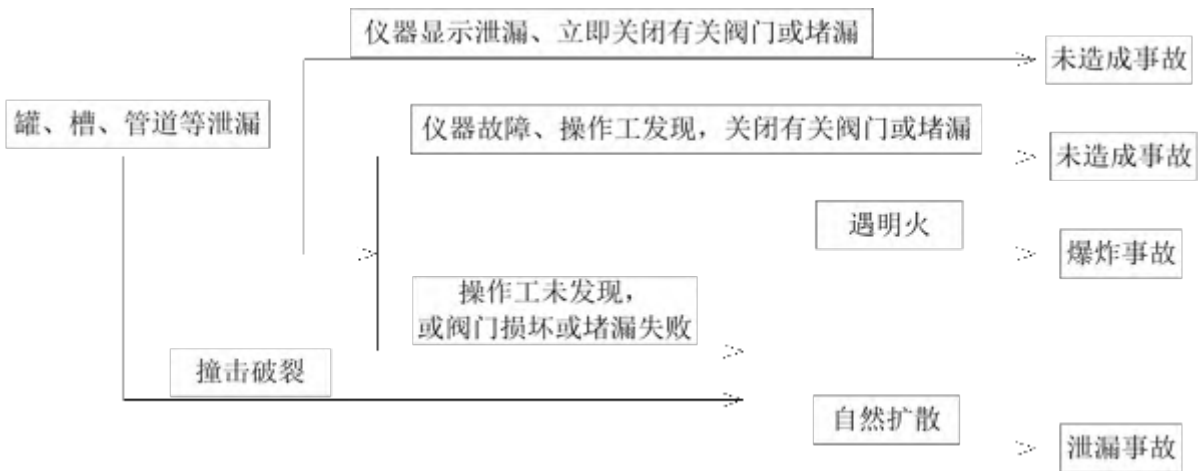

5.6-1



5.6-2

---

**5.6.5.4**

**1**

**5.6-23a**

**2**

**5.6.5.5**



---

---

**5.6.7**

**1**

---

2

3

$$= x \times x \quad (x) \times \quad - \quad + \quad x \quad + \quad +$$



**5.6-25a**

**5.6-25b**



5.6-25d

5.6.7

**Nb**

$$R_i = \frac{\left[ \frac{g(Q_1 / \rho_{rel})}{D_{rel}} \times \left( \frac{\rho_{rel} - \rho_a}{\rho_a} \right) \right]^{1/2}}{U_i}$$

$$R_i = \frac{g(Q_1 / \rho_{rel})^{1/2}}{U_i^2} \times \left( \frac{\rho_{rel} - \rho_a}{\rho_a} \right)$$

5.6-26







---

---

--	--	--

5.6.5.3

5.6-29

5.6.5.4

1

5.6-30

vpt

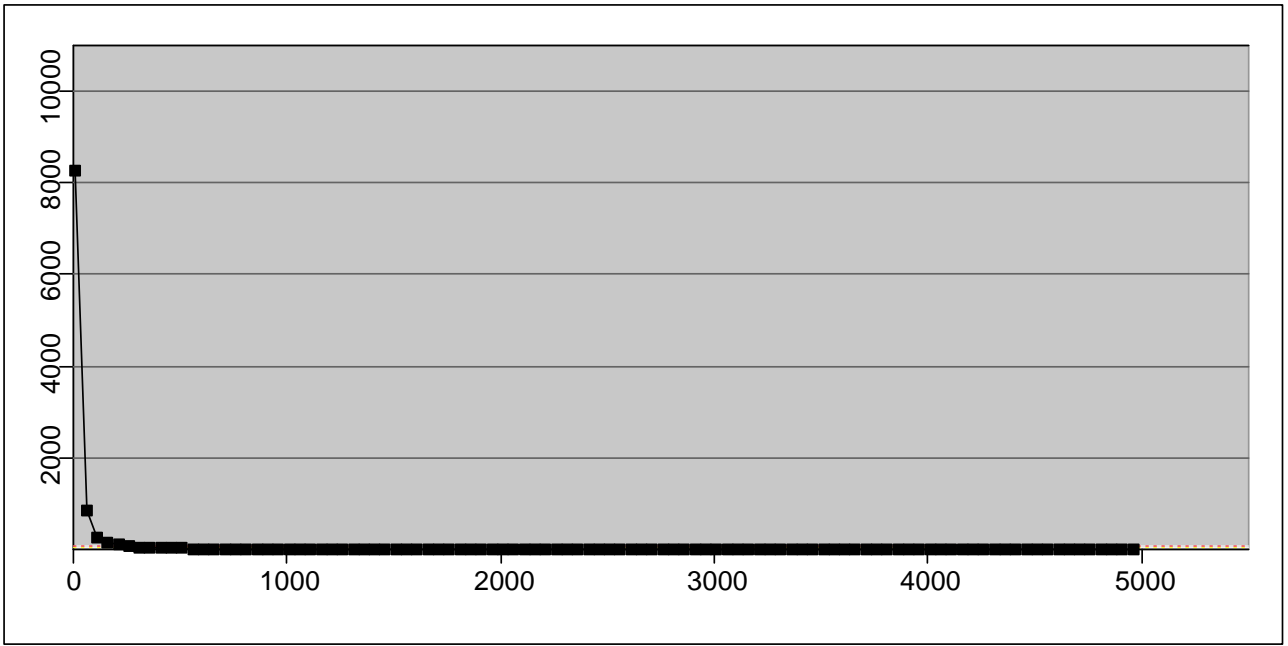

**5.6-3**

**5.6-4**

---

2

CO

5.6-31

CO

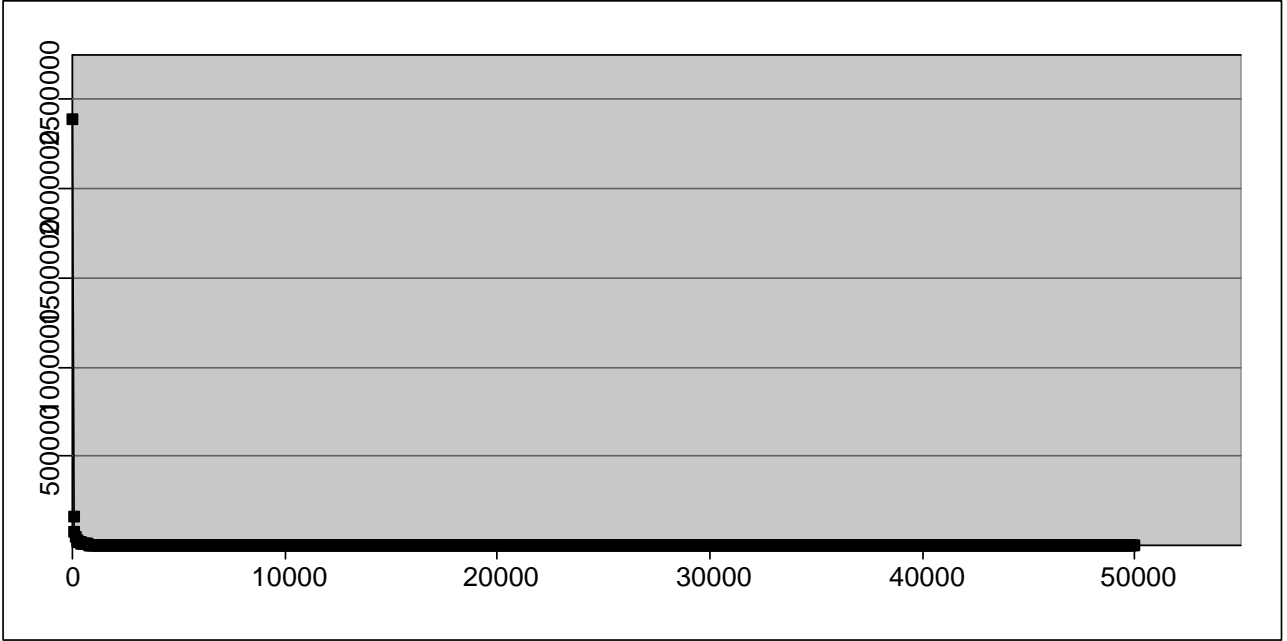

5.6-5

CO

5.6-6

CO



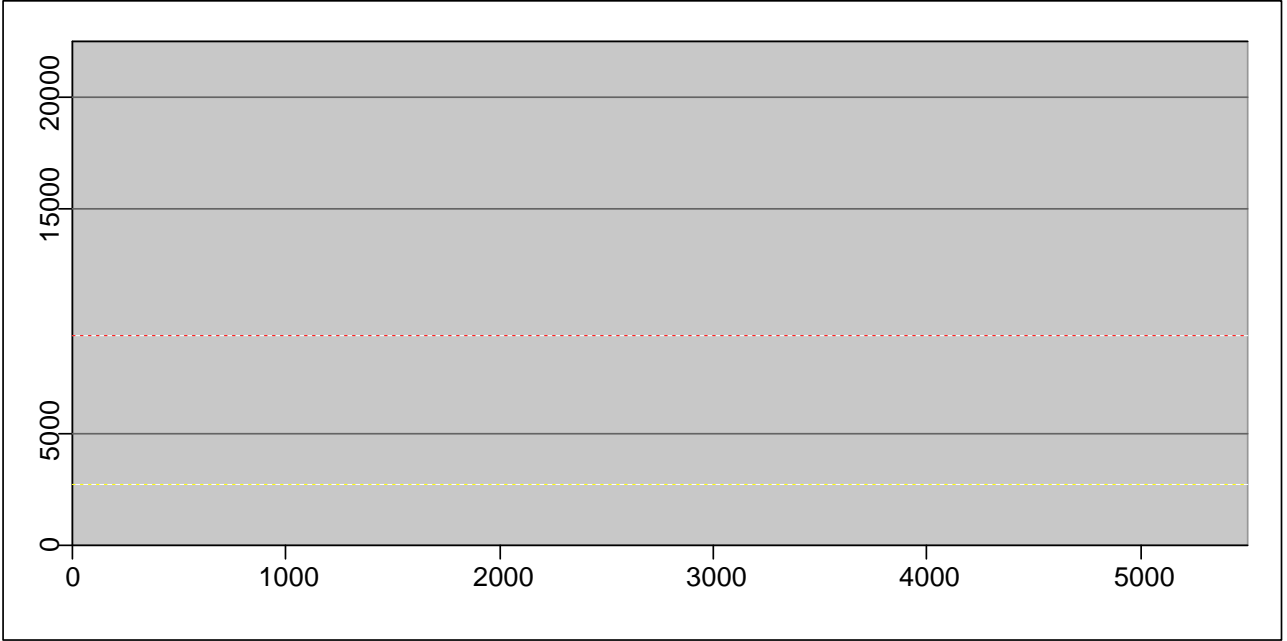



---

---

5.6.8.2

---

**5.6.8.3**



---

**5.6.9**

**5.6.9.1**













5.6-34







5.6.9.2



5.6-36

5.6.9.3



---









**1**

**I**

**2**

**II**

**3**

**III**

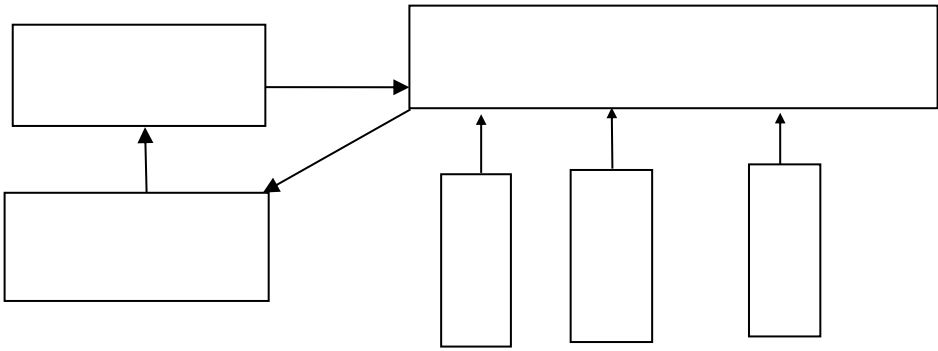











**5.6.10**

5.6-37

1	50	/						G1-1		2
			DA019	43.7	D	1.4			G1-2	2
				DA020		31.9	D	1.0		
2	30	/						G2-1		2
			DA021	30.9	D	1.0			G2-2	
2				DA022		25	D	1.2		
3								G4-1		2
			DA002	51	D	0.8			G5-1	
2						DA011	51	D	0.9	
G5-2								DA010	50	D 0.85
			G6-1							DA018
15	D	1.0						G7-1		C
DA024	15	D	0.3							

2 50 / 3

100 / 3

10 / 3

# ČASOPIS

(ž 7) SR

19

W

■ ■

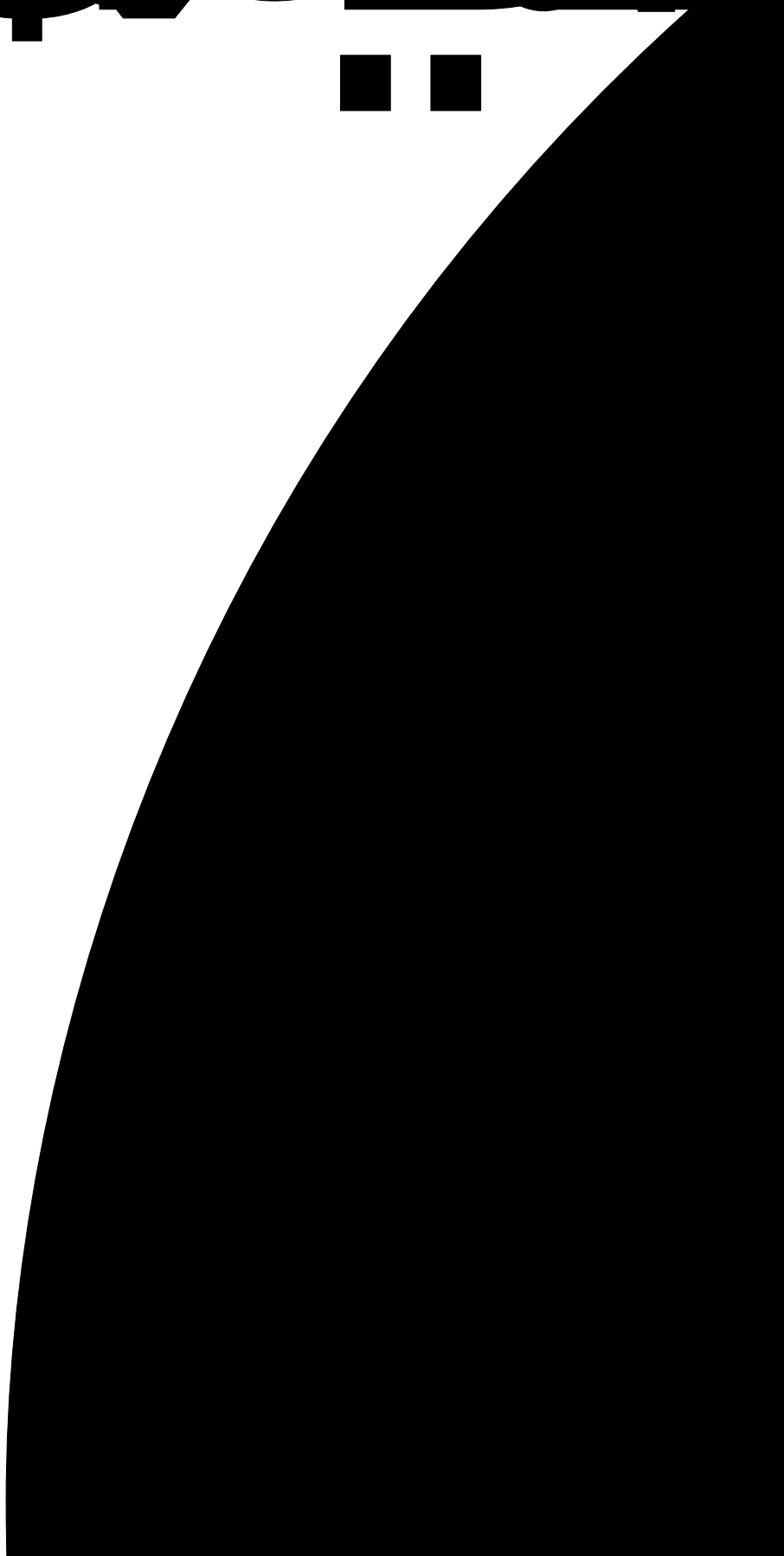



4  
-30  
-50  
-63 -110

1000 1500  
C C

:  
:

1

0.7 0.6 0.6 0.9  
15% 30%

2

15% 20%

3

---

---

60 / 3

50 / 3

2013

60 / 3

85%

45%

85%

C

2

( )

( 2-

2 2)

2

2-

2 2

C

$$2+3 \quad 2= \quad 2 +2 \quad 2 \quad 8+8 \quad 2=8 \quad 2$$

C      C<sub>2</sub>

$$C + 2 = 2 + C_2$$

$$C_{2+2} \quad 2 = 2 \quad 2 + C_2 \quad 2 \quad C_2$$

2

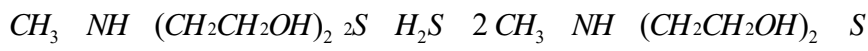
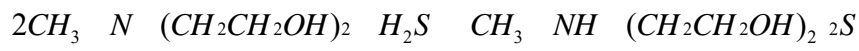

C<sub>2</sub>

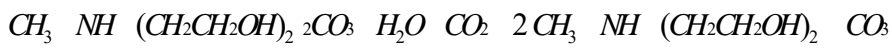
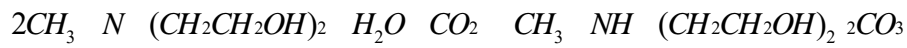

2    C      C<sub>2</sub>

2

20%    DEA

2

2

2

2

C<sub>2</sub>

2

---

---

0.3

2

40

1500

500

419.61 <sup>3/</sup>

19.96 <sup>3/</sup>

C D

C D

GB3838-2002

(DB37/3416.5-2018) 2

300

80 <sup>3/</sup>

6.2-2

		<sup>3/</sup>		C D				
1		64.76	5 6	15106	6039.5	12611	199.6	12.4
2		120	-	20000	10000	15000	300	-
3			-	-			-	-
4		64.76	7 6	1200	50	40	60	12.4

5			120	7	-	60	60	-	-
6				-	-			-	-

2

1

350<sup>3/</sup> 9589<sup>3/</sup>

+       +       +       +A/ +       +       +       +

+       2720<sup>3/</sup>       6869<sup>3/</sup>

419.61<sup>3/</sup>

2

C D

C D

6.2-4

		<sup>3/</sup>		C D /	/	/	/	/
1		350	6 9	1000-1500	50	30	30	70
2		350	6 9	40	2	1	0.3	0.1

6.2-4

C D

GB3838-2002

(DB37/3416.5-2018) 2

1

---

---

100

AC

A

10 100

A/

2

60%

3 C D<sub>C</sub>

A/ +

+

4

A/ +

+

3-

2

C 2 2

3-

3-

C D<sub>C</sub>

300

1

1

---

2

2

1

2

3

4

65 B(A)

GB 1-2006

10

2020 6 9

2020 D 126-

GB12348-2008 3

65 B A

55 B A

39.6 /

2421.74 /

50

49

29

13

08

6-10



---

---

18597-2001

GB

GB18597-2001 A

GB18597-2001

2

2

1

$10^{-10}$  /  $10^{-7}$  /

			118.363 37.409	220	20 1:3 2 60 C15 150 3:7	GB18597-2001	1 10 <sup>-7</sup> / 2 2 10 <sup>-10</sup> /	
			118.398 37.407	90 2	20 1:3 2 60 C15 150 3:7			

6.5-1

1		+43.7	2 DB37/2376-2019 1
2		+31.9	
3		+30.9	
4		+25	
5		+ DEA +51	2 DB37/2376-2019 1
6		+51	2
7		+50	DB37/2376-2019 1
8		+ + + 1 15	DB37/3161-2018 2
9		DA +	C 6
10		+ +15	DB37/2601.6-2019 3 C
11		+	GB37822-2019
12			2

			(GB16297-1996) 2
			GB31570-2015 3 95%
13			DB37/3161-2018 2
1			C D
2			GB3838-2002  (DB37/3416.4-2018) 2
1			(GB18597 2001)
2			GB18599-2001
1		+ +	GB12346-2006 3
1			GB/ 14848-2017
1			
2			

---

---

3			









---

---

# 8

## 8.1

### 8.1.1

1

4

22

8.1-1

#### 8.1-1

1				1
				1
				4
2				2
				20
				9
3			38	

### 8.1.2

1

1

2

3

4

---

5

6

7

2

1

2

3

4

3

1

2

3

### 8.1.3

[1980]65

1

2

3

4

[2011]35

[208]114



1

2

3

4

5

6

8.2

8.2.1

8.2-1

8.2-1

			SO <sub>2</sub> NO <sub>2</sub>	2 2	
			SO <sub>2</sub> NO <sub>2</sub>		
			SO <sub>2</sub> NO <sub>2</sub>		
			H <sub>2</sub> S VOC		
			VOC		
			SO <sub>2</sub> NO <sub>2</sub>		
			SO <sub>2</sub> NO <sub>2</sub>		
			SO <sub>2</sub> NO <sub>2</sub>		
			SO <sub>2</sub> NO <sub>2</sub>		
			SO <sub>2</sub> NO <sub>2</sub>		
		45m	SO <sub>2</sub> NO <sub>2</sub>		
				2 2	
			H COD NH <sub>3</sub> -N		/
		1m	Ld L		
				1	

8.2.2

		VOC	10	2
		H		
			14	

8.2.2

VOC

8.2-2

					2
			1m 1.5m	VOC	2
				VOC	

8.2-2

	500m	H COD DO BOD <sub>5</sub>	
			30
		GB36600	
	200m		

---

## **8.2.3**

### **8.2.3.1**

1

2

### **8.2.3.2**

---

---

6

3

$$D=2AB / A+B \quad A \quad B$$

5m/

1.5

2

1.5m<sup>2</sup>

1.1m

8cm

200kg/m<sup>2</sup>

1.2m 1.3m

2

80mm

50mm

40mm

3

2m

GB4053-208

2m

Z

45

1.2m

750mm

GB4053-208

1

1

2

HJ/T81



---

---

2

600mm

300mm

2m

3

GB15562.1

[2003]85

4

5

6

7

GB15562.1-1885

GB15562.2-1885









8.2-3

8.2-6

8.2-1



**8.2-3**

8.2-4





1				
2				
3				
				
4				

8.2-1

8.2-5

1			<p>1 40 40cm</p> <p>2 3 80cm</p>
2			<p>1 2 3 4 120cm</p> <p>80cm</p>
3			<p>1 20 20cm</p> <p>2 3</p>
4			<p>1 8 8cm</p> <p>2 3</p>

8.2-6

Explosive			
Flammable		Harmful	
Oxidizing			
Irritant		Asbestos	

8.2.4

8.2-7

8.2-7

	A90		5
	A90		

	A90	MTBE	
	A90		
	A90		
	7820A	CO CO <sub>2</sub>	1
	SP6890		8
	SP6890	C4	
	SP6890		
	SP6890	8	
	SP6890		
	SP6890		
	SP6890		
	SP6890	CO CO <sub>2</sub>	
	GCA96		2
	GCA96		
	NK-81A		1
	ZWK-2001		1
	UPT-1-87		1
	SYD-6536B		1
	1260		1
	SENSOR27		1
X	KL3120		1
LC-6	LC-6		1
	WGE-2000		1
	DDS-11A		1
PH	PHS-3C		1
	CP224C		1
	CP282		1
KDM	KDM		1
COD	ZQ-8	COD	1
	HD-2012M		1
DL-60D	DL-60D		1
HK-508	HK-508		1
VIS-7200A	VIS-7200A		1
			1
			1
	5E-MF6000		2
	DZF		1
	JC-2000E		1

---

---

	TWK-2000		1
			1
			17
		COD	1

### 8.2.5

### 8.2.6

### 8.2.7

1

2

3

### 8.2.8

























“ ”







--	--	--



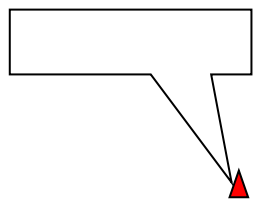

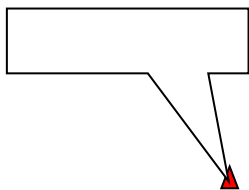

3

11



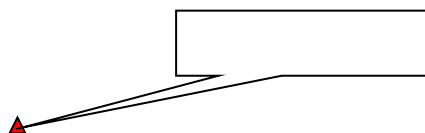



WORLDWIDE

WORLDWIDE

EB









---

**11**

**11.1**

**11.1.1**

**11.1.2**

**11.1.3**



---

---

**11.2.2**

1

2

---

---

11.2-2

		t/a	t/a	t/a

11.3





0 /  
 2102-3 0 02-0 -02-320 4 2100 2 11  
 1 000<sup>2</sup> 1.

0  
 000 2020 12

201

2012-2030

□  
 1 □  
 1 0 / 1-1 2  
 □ 01 43. 1.4 1-2 2  
 □ 020 31. 1.0  
 2 30 / 2-1 2  
 □ 021 30. 1.0 2-2  
 2 □ 022 2 1.2  
 3 □ 4-1 2  
 002 1 0. -1  
 2 011 1 0.  
 -2 2 010 0 0.  
 -1 01  
 1 1.0 -1  
 024 1 0.3  
 4  
 ○ 01

	0 /			
		1. / <sup>3</sup>	. / <sup>3</sup>	4. / <sup>3</sup>
	43 <sup>3/</sup>	000	0%	
		01		0.11 /
4.4 /	0.3 /	0.014 /	0. /	0.04 /
		01		
		3 /23 -201	2	
	10 / <sup>3</sup>	2 0 / <sup>3</sup>	100 / <sup>3</sup>	
○	020			
	0 /			
		1. / <sup>3</sup>	3 .3 / <sup>3</sup>	4. / <sup>3</sup>
	<sup>3/</sup>	000	0%	
		020		0.11 /
2.4 /	0.32 /	0.014 /	0.311 /	0.040 /
		020		
		3 /23 -201	2	
	10 / <sup>3</sup>	2 0 / <sup>3</sup>	100 / <sup>3</sup>	
○	021			
	30 /			
	. / <sup>3</sup>	44. / <sup>3</sup>	4. / <sup>3</sup>	204 <sup>3/</sup>
000		4.11%		
		021		0.11 /
0.0 4 /		0.014 /	0.10 /	0.011 /
		021		
		. / <sup>3</sup>	44. / <sup>3</sup>	4. / <sup>3</sup>
		3 /23 -201	2	
10 / <sup>3</sup>	2 0 / <sup>3</sup>	100 / <sup>3</sup>		
○	022			



○ 010

010

1. / <sup>3</sup> . / <sup>3</sup> 4.2 / <sup>3</sup>  
 31 <sup>3/</sup> 000 0%

0.42 / 1 . 3/ 1.1 /

3 /23 -201 2

10 / <sup>3</sup> 2 0 / <sup>3</sup> 100 / <sup>3</sup>

○ 01

01

0.41 / <sup>3</sup>0.00 / <sup>3</sup>3. / <sup>3</sup>0.1 / <sup>3</sup>

31

2313 <sup>3/</sup>

000

1 %

0.0 4/

0.001 /

0. 2 /

0.03 /

3 /31 1-201

1

10 / <sup>3</sup>20 / <sup>3</sup>3.0 / <sup>3</sup>100 / <sup>3</sup>

00

2

1

2

3

4

1

○ 0 /

1-1 1-2 1-3

□

1-4

○ 30 /

2-1 2-2 2-3

2

2-4

○

4-1

4-2

3-1

-1

10

11

13

12

14

□

2

41 . 1 <sup>3/</sup>

1 . <sup>3/</sup>

3 3 -2002

( 3 /341 . -201 ) 2

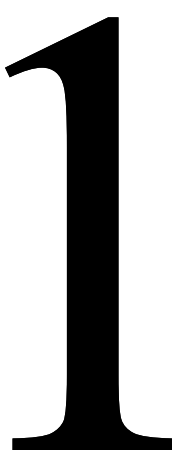
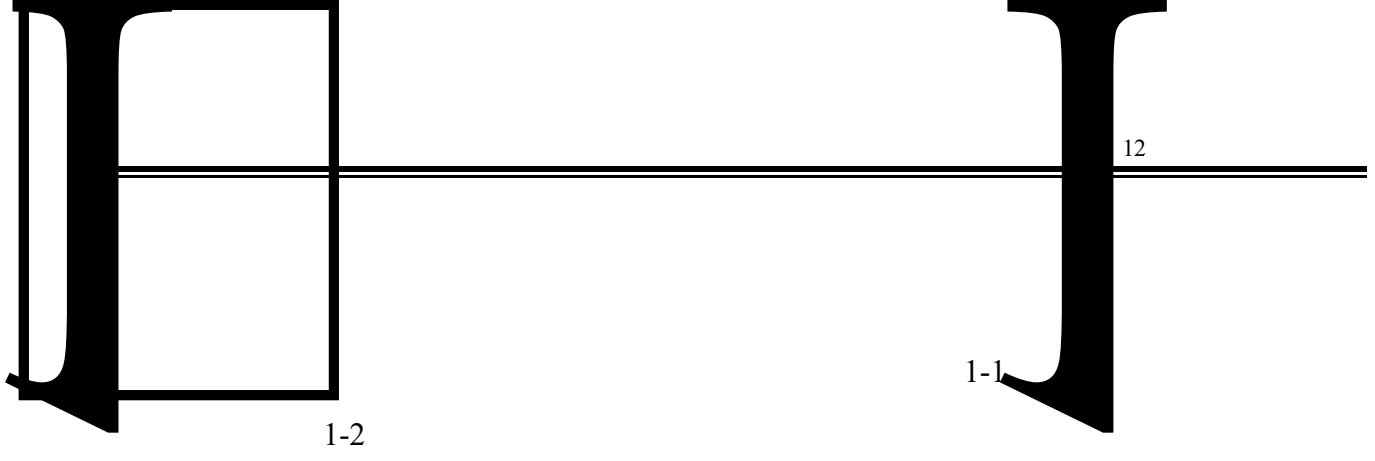

24

24

30 -2012

10 □ 2.

24

3

2.2-201

30 -2012

3.

1.1

2.

#

1.20

3 3 -2002

□

1

1# #

2.3

.

4. 1

12.31

□

.40

2. 0

1 . 2

1#

.

3#

#

1. 4

/ 14 4 -201

□

2

1#

2#

/ 14 4 -201

---

---

1#                    2#

2020

1134 -200                    3

3 00-201

1  
100%  
2  
2  
3  
3  
1  
-20%  
10  
4  
2  
1



1 -2001

1 -2001

2 . / 2 .  $10^3$  /

3 00-201

10- 40

4 00 /

1000

-2 0

1

-1

1

-2

310

2

-1

4010

-2

113 0

21

2

31

3

2

2

3

-1

210

-2

0

1

2

.3

201

201 2020

2012-2030

201 2020

2011 3

2

( 2012 )

( 201 )

201 -2020

-0 - 4-04

10

2.

10

30 -2012

□

3 3 -2002

/ 14 4 -201

2013 2020

201 2020

3

2. 10

2. 10 2020

4 / 3 / 3

100%

. 0.3

□

41 . 1 3/

1 . 3/

3 3 -2002

( 3 /341 . -201 ) 2

0 / 1. /

201 1 2

2

( )

1. 2 / 1 . / 2. 14 /



12.2-1

		+ +1	3
11		+	3 22-201
12			2 ( 1 2 -1 ) 2 31 0-201 3 %
13			3 /31 1-201 2
1			3 3 -2002
2			( 3 /341 .4-201 ) 2
1			( 1 2001)
2			1 -2001
1		+ +	1234 -200 3
1			/ 14 4 -201

---

---

1				
2				
3				

1

2

3

4

14000

1			+43.	
		01		2
			+31.	3 /23 -201 1
		020		
			+30.	
		021		
			+2	
		022		
		002	+ 1 + +	2 3 /23 -201 1
			+ 1	
	011		2	
		+ 0	3 /23 -201 1	
	010			
		+ +		
	01	+ 1 1	3 /31 1-201 1	
		+ +		
		+1	3 /2 01. -201 3	

			+	3 22-201 2	
				( 1 2 -1 ) 2	
				31 0-201 3 %	
				3 /31 1-201 2	
1				3 3 -2002	
2				( 3 /341 . -201 ) 2	
1				1134 -200 3	

1			( 1 2001)	
2			1 -2001	
1			2011	
2			2011 104	
3				









山东神驰化工集团有限公司（单位）承诺所填写各项内容真实、准确、完整，建设项目符合相关产业政策规定。如存在弄虚作假情况及由此导致的一切后果由本单位承担全部责任。

法定代表人或项目负责人签字：\_\_\_\_\_

备案时间：2021-2-8



理后，达标排放。

(三) 对生产中产生的固体废物应分类处置，废碱液和污水处理厂产生的污油渣、浮渣、污泥属于危险废物，立足于综合利用，不能综合利用的须进行无害化处理，废催化剂由生产厂家回收利用。

(四) 优化厂区平面布局，选用低噪声设备，对强噪声源应采取相应的隔音、消声和减震措施，确保厂界噪声达到《工业企业厂界噪声标准》(GB12348-1990) III类标准要求。

(五) 按照排污口设置及规范化整治管理的要求规范化设置各类排污口。

(六) 本项目建成后，原有的 10 万吨/年的重油改质装置停止生产。

三、本项目污染物年排放总量指标初步核定为：

(一) 水污染物：COD24.64 吨/年、石油类 0.58 吨/年；

(二) 大气污染物：二氧化硫 231.74 吨/年。

四、要做好厂区的平面调整，各装置的卫生防护距离应符合《石油化工企业卫生防护距离》(SH3093-1999) 规定，本项目卫生防护距离确定为 800 米。

五、按 ISO14000 标准体系要求加强环境管理，加强危险化学品管理，落实环境影响报告书提出的环境风险防范措施，制定应急预案，厂内须设置足够容量的雨水集水池和事故应急池，严禁废水未经处理直接排放。储罐区设置围堰，









产业园区郝纯路129号。项目以劣质油为原料，经过初馏、减压等工艺，年加工劣质油260万吨，年生产重交沥青200万吨、蜡油34.58万吨、石脑油3.38万吨、柴油21.26万吨、净化干气0.795万吨，并副产硫磺、15%氨水。本项目总投资9747.59万元，其中环保投资80万元。项目属于备案制（东营市发展和改革局登记备案号：0805DT048）。项目未批先建，按照《山东省人民政府关于印发山东省清理整顿环保违规建设项目工作方案的通知》（鲁政字〔2015〕170号）的要求，属于规范类项目，已经依法查处。

## 二、项目整改和运行管理中应着重做好以下工作：

（一）废气污染防治。两台加热炉均以脱硫干气为燃料，分别经60米、58米高排气筒排放；外排烟气中烟尘、SO<sub>2</sub>、NO<sub>x</sub>达到《石油炼制工业污染物排放标准》（GB31570-2015）表3标准。项目依托的硫磺回收装置尾气焚烧炉外排烟气中SO<sub>2</sub>达到《石油炼制工业污染物排放标准》（GB31570-2015）表3标准，NO<sub>x</sub>达到《大气污染物综合排放标准》（GB16297-1996）表2标准，烟尘达到《山东省固定源大气颗粒物综合排放标准》（DB37/1996-2011）表2标准。安装烟气在线监控设备并与环保部门联网。加强无组织废气污染物控制措施，以新带老，全厂实行LDAR（泄漏检测与修复）技术；石脑油、柴油储罐全部采用内浮顶；装置区设置密闭采样器，酸性水采用管线密闭负压输送；配套油气回收设施，厂界非甲烷总烃达到《石油炼制工业污染物排放标准》（GB31570-2015）表5标准；硫化氢、氨、臭气浓度达



























# 东营市环境保护局

东环审〔2016〕171号

---

## 关于山东神驰化工集团有限公司 160万吨/年渣油加氢脱硫及配套制氢项目 环境影响报告书的批复

山东神驰化工集团有限公司：

你公司《160万吨/年渣油加氢脱硫及配套制氢项目环境影响报告书》收悉。经我局建设项目联审会议（2016年第12次）研究，按照环境影响报告书所列项目的性质、规模、工艺、地点和拟采取的环境保护和风险防控措施，该项目污染物可达标排放，主要污染物排放符合总量控制要求。批复如下：

一、建设项目基本情况。项目位于东营区史口镇生态化工循

— 1 —



















(五) 严格落实环境风险防范措施，制定相应的环境风险应急预案并纳入全厂环境风险应急联动机制。加强对锅炉各系统装置的运行管理。配备必要的应急设备，定期开展环境风险应急培训和演练，切实加强事故应急处理及防范能力。化学危险品等按规定妥善管理。

四、污染物总量控制。项目建成后，烟尘、二氧化硫、氮氧化物排放总量分别控制在 2.7 吨/年、8.8 吨/年和 24.6 吨/年之内；比原燃煤锅炉排放分别减少 0.18 吨/年、0.8 吨/年和 1.0 吨/年，符合我区“十三五”总量控制的要求。

五、项目建成后应自主进行建设项目竣工环境保护验收，经验收合格后方可正式投入生产。

六、该公司环保“三同时”制度和日常环保监管工作由东营分局环境监察大队具体负责，依法监管确保落实环保“三同时”制度，杜绝违反环保法律法规现象发生。



## 建设项目竣工环境保护 验收申请表

项目名称 120万吨/年重油催化裂解(DCC)装置项目

建设单位 山东神驰化工有限公司 (盖章)

建设地点 东营市东营区郝纯路129号

项目负责人 牛荣海

联系电话 0546-8286808

邮政编码 257082

环保部门	收到验收申请表日期	
填写	编号	东环验[2010]00015

国家环境保护总局制

## 说 明

1. 本表根据《建设项目竣工环境保护验收管理办法》编制。
2. 本表为建设单位申请建设项目竣工环境保护验收的必备材料之一，需在正式申请验收前按要求由建设单位填写。
3. 表格中填不下或仍需另加说明的内容可以另加附页补充说明。
4. 封面建设单位需加盖公章。
5. 本表属国家级审批须一式 6 份，属省级审批须一式 5 份，属地市级审批须一式 4 份。
6. 本表主送负责建设项目竣工环保验收的环境保护行政主管部门，在正式审批后分送有关部门存档。





表三

	排放口编号	污染物	排放浓度 (毫克/升)	执行标准	排放总量 (吨/年)	允许排放量	排放去向
废水监测结果	01	COD	89	120	13.05	24.64	五千排
		氨氮	7.03	25	0.99		
		石油类	4.0	10	0.58		
	排放口编号	污染物	排放浓度 (毫克/立方米)	执行标准	排放总量 (吨/年)	允许排放量	排气筒高度
废气监测结果		二氧化硫	4	550	1.74	231.74	80
		烟尘	27.6	120	11.8		
		氮氧化物	170	240	72.9		
厂界噪声监测	噪声测点编号	监测值 (dB(A))	执行标准	其它			
	1#	昼: 55.9 夜: 51.3	65 (昼) 55 (夜)				
	2#	昼: 53.9 夜: 48.1					
	3#	昼: 57.4 夜: 50.3					
	4#	昼: 64.6 夜: 54.1					

注: 1. 废水中汞、镉、铅、砷、六价铬总量单位为千克/年, 其他项目总量单位均为吨/年。

2. 废气中各项污染物总量的单位为吨/年。



表五

验收组成员名单

	姓名	单 位	职务、职称	签名
组长	张永军	东营环保分局	副局长	张永军
副组长	张春娥	东营市环保局科监科		张春娥
	许桂英	东营环保分局管理科		许桂英
	宋金江	东营环保分局监察大队		宋金江

表六

行业主管部门验收意见:	
(公章)	
经办人(签字):	年 月 日
地方环保行政主管部门验收意见:	
<p>经初步审查,山东神驰化工有限责任公司120万吨/年重油催化裂解(DCC)装置项目,在实际生产与建设中已按环评批复的要求进行了落实。经市环境监测站监测,主要污染物排放指标均符合国家排放标准,现已具备环保验收条件和验收要求,同意上报市局。</p>	
经办人(签字): 许桂英	 2009年9月4日





# 东营市环境保护局

东环审〔2015〕204号

---

## 关于山东神驰化工集团有限公司 200万吨/年重交道路沥青装置项目 竣工环境保护验收批复

山东神驰化工集团有限公司：

你公司报送的《关于山东神驰化工集团有限公司200万吨/年重交道路沥青装置项目竣工环境保护验收申请报告》及相关材料收悉。经现场检查及建设项目联席会研究（2015年第26次专题会议），批复如下：

一、该项目位于史口镇生态化工循环经济产业园区郝纯路129号，山东神驰化工集团有限公司现有厂区内。项目建设200

— 1 —

万吨/年重交道路沥青装置，年加工劣质油 260 万吨，生产石脑油 3.38 万吨，柴油 21.26 万吨，蜡油 34.58 万吨，重交沥青 200 万吨。项目总投资 9747.59 万元，其中环保投资 80 万元。2015 年 8 月，东营市环保局对青州市方元环境影响评价服务有限公司编制的《山东神驰化工集团有限公司 200 万吨/年重交道路沥青装置项目环境影响报告书》（东环审〔2015〕174 号）进行了批复。2015 年 8 月 21 日经市环保局东营分局批准投入试运行。东营市环境监测站于 2015 年 9 月 15 日-16 日对该项目进行了现场监测，市环保局于 2015 年 10 月 18 日组织有关人员进行了现场检查。

二、项目减压塔分离器、减粘塔回流罐、硫磺回收产生的急冷酸性水由酸性水汽提装置处理，产生的净化水部分回用，其余一部分占成置成液、机泵冷却水、真空泵排污水、地面冲洗水、生活污水、初期雨水送厂区自备污水站，经过“隔油+气浮+两级生化+氧化杀菌”处理达到地表水五类水质标准后经七支渠外排五千排。两台加热炉均以脱硫干气为燃料，分别经 60 米、58 米高排气筒排放。酸性气处理由环评中的依托硫磺回收装置变更为依托公司建设的废酸再生装置，市环境监测站对废酸再生尾气进行了补测。石脑油、柴油储罐全部采用内浮顶，酸性水采用管线密闭输送；配套了油气回收设施。污水处理站新增油污和浮渣、罐底油泥委托有处理资质的单位处置。对泵类、风机、压缩机、空冷器等主要噪声源采取了减振、消音、隔音等措施。公司制定了应急预案并已备案，配备了必要的应急设备，并进行了演练。

事故废水处理依托 5000m<sup>3</sup>事故应急池，建设了雨污切断装置，设置了规范的污染物排放口、采样孔口和采样监测平台。

三、东营市环境监测站编制的《山东神驰化工集团有限公司 200 万吨/年重交道路沥青装置项目验收监测报告》表明，验收监测期间：

（一）减压加热炉、减粘加热炉废气中烟尘、氮氧化物、烟尘均符合《石油炼制工业污染物排放标准》（GB 31570—2015）表 3 标准。

废酸再生尾气中 SO<sub>2</sub>、硫酸雾、NO<sub>x</sub> 均满足《硫酸工业污染物排放标准》（GB26132-2010）、《大气污染物综合排放标准》（GB 16297-1996）标准要求。

厂界监控点浓度最高值非甲烷总烃符合《石油炼制工业污染物排放标准》（GB 31570—2015）表 5 标准；氨、硫化氢、臭气均符合《恶臭污染物排放标准》（GB14554-93）中二级标准。

（二）项目外排废水污染物最大日均值 pH、氨氮、石油类、总磷、挥发酚、硫化物、砷、汞、六价铬、铅，均符合地表水五类水质标准。

（三）验收监测期间，该项目厂界昼间、夜间噪声均达到《工业企业厂界环境噪声排放标准》（GB12348-2008）3 类标准要求，北厂界夜间噪声超标（主要为运输噪声），附近无居住区等敏感目标。

（四）项目二氧化硫、氮氧化物、化学需氧量、氨氮排放总量均满足项目批复总量要求。

四、本项目经过整改，基本落实了环评及批复中的各项环保措施，主要污染物达标排放，符合建设项目竣工环境保护验收条件，项目竣工环境保护验收合格。

五、项目投运后，你要按照要求加大 VOCs 治理力度，尽快实施 LDAR，进一步加强各项环保设备运行管理，确保污染物稳定达标排放；如遇环保设施检修、停运等情况，要提前向当地环保部门报告，并如实记录备查；认真落实各项环境风险防范措施，定期开展突发环境污染事故应急演练，降低环境风险。

六、由东营分局负责该项目的环境日常监督检查。



---

抄送：市环境监察支队，东营分局。

---

东营市环境保护局办公室      2015年11月17日印发

---









































### 七、验收人员信息

验收组		姓名	单位	职务/ 职称	签名
组长	建设单位	张相斌	山东神驰化工集团有 限公司	安环部部长	
	专家	宋德海	东营市环境监测站	高工	
	专家	张茂华	东营市石化集团总公 司	高工	
成员	专家	刘秀梅	东营市环境监测站	高工	
			东营市环境监测站		















## 七、后续管理要求及建议

1、项目完成自行验收之后 5 日内需进行网上公示，公示期不少于 20 天。

2、验收报告报送环保部门备案时应同时报送验收报告公示情况说明及验收整改报告。

3、明确项目运行期间监测计划及落实，做好环保设施维护及运行管理记录，确保“三废”达标排放。

山东神驰化工集团有限公司

2018 年 6 月 30 日





7





较高。已入驻山东万通石油化工集团有限公司、胜利油田分公司石油化工总厂、山东神驰化工集团有限公司、山东宝莫生物化工股份有限公司、山东海科化工集团有限公司等 28 家企业。产业园内现有 7 个村庄（大赵村、小赵村、十一图村、小刘村、吕家村、范家村、三里村），已制定搬迁计划。

### （三）存在的主要问题

东营区化工产业园是由现有史口镇生态化工循环经济产业园已开发区域和郝家镇南部与史口镇接壤区域组成，目前存在的主要问题如下：

1. 园区规划范围内涉及 7 个村庄（1092 户、2790 人），大赵村、小赵村、三里村、范家村、吕家村、十一图村、小刘村需要搬迁。东营区政府、垦利区政府承诺 2020 年 6 月前全部搬迁。

2. 园区现有集中式污水处理厂（史口镇污水处理厂）1 处，处理能力暂不能满足所有园区污水处理需要，胜利油田分公司石油化工总厂、山东神驰化工集团有限公司、山东海科化工集团有限公司等企业污水利用自有污水处理厂处理。

3. 园区集中供热设施正在建设尚未竣工，现由 18 家企业的 31 台工业小锅炉和 1 台采暖用小锅炉供热。园区集中供热项目预计 2019 年 5 月底建成投产。

4. 本规划发展方向与《石化产业规划布局方案》（发改产业〔2014〕2208 号）、《郝家镇土地总体规划》（2006-2020）和《史口镇土地利用总体规划》（2006-2020）总体衔接，但需要部分调











































































































80 /

2020 11

0 /

-

-

2001 12

12

2012

120

/

200 /

0 /

1. /

20 /

1 0 /

3 0 3/

2 0 /

201 1 1

13 0 02 33 1 3

001

201

1

1

2020

12 31

0

/

1.

/

0 /

30 /

1.

/

30 /

30 /

0 /

□ 1. /

30 /

30

/

□

0 /

0 /

2020-3 0 02-2 -03-01

2100

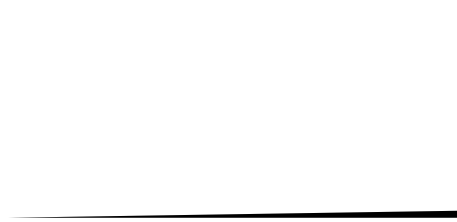

1

2

1

2

3

3

1

2

